

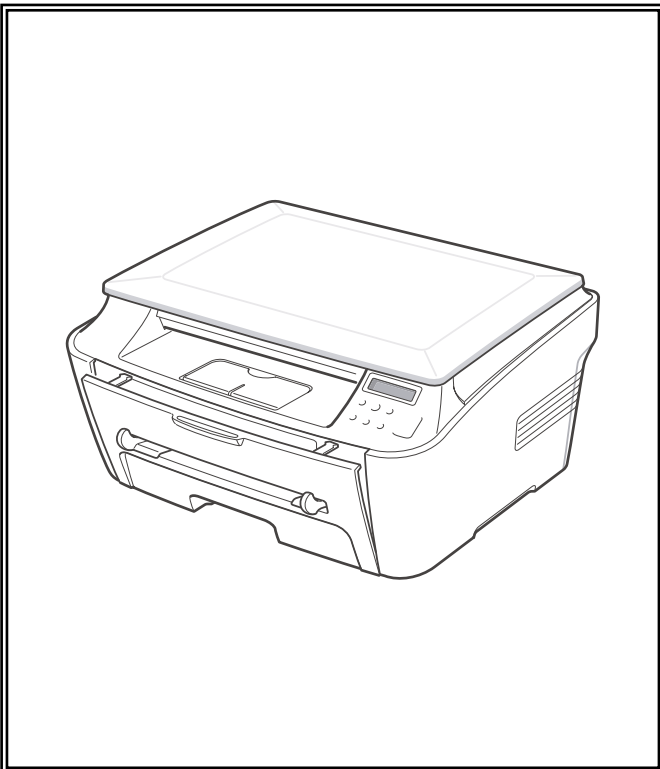

DIGITAL LASER MFP SCX-4100

SERVICE *Manual*

DIGITAL LASER MFP



CONTENTS

1. Precautions
2. Reference Information
3. Specifications
4. Summary of product
5. Disassembly and Reassembly
6. Alignment and Adjustments
7. Troubleshooting
8. Exploded Views and Parts List
9. Block Diagram
10. Connection Diagram

1. Precautions

In order to prevent accidents and to prevent damage to the equipment please read the precautions listed below carefully before servicing the printer and follow them closely.

1.1 Safety Warning

(1) Only to be serviced by appropriately qualified service engineers.

High voltages and lasers inside this product are dangerous. This printer should only be serviced by a suitably trained and qualified service engineer.

(2) Use only Samsung replacement parts

There are no user serviceable parts inside the printer. Do not make any unauthorized changes or additions to the printer, these could cause the printer to malfunction and create electric shock or fire hazards.

(3) Laser Safety Statement

The Printer is certified in the U.S. to conform to the requirements of DHHS 21 CFR, chapter 1 Subchapter J for Class 1(1) laser products, and elsewhere, it is certified as a Class I laser product conforming to the requirements of IEC 825. Class I laser products are not considered to be hazardous. The laser system and printer are designed so there is never any human access to laser radiation above a Class I level during normal operation, user maintenance, or prescribed service condition.

Warning >> Never operate or service the printer with the protective cover removed from Laser/Scanner assembly. The reflected beam, although invisible, can damage your eyes. When using this product, these basic safety pre-cautions should always be followed to reduce risk of fire, electric shock, and injury to persons.



CAUTION - INVISIBLE LASER RADIATION
WHEN THIS COVER OPEN.
DO NOT OPEN THIS COVER.

VORSICHT - UNSICHTBARE LASERSTRAHLUNG,
WENN ABDECKUNG GEFFNET.
NICHT DEM STRAHL AUSSETZEN.

ATTENTION - RAYONNEMENT LASER INVISIBLE EN CAS
D'OUVERTURE. EXPOSITION DANGEREUSE
AU FAISCEAU.

ATTENZIONE - RADIAZIONE LASER INVISIBILE IN CASO DI
APERTURA. EVITARE L'ESPOSIZIONE AL
FASCIO.

PRECAUCION - RADIACION LASER INVISIBLE CUANDO SE ABRE.
EVITAR EXPONERSE AL RAYO.

ADVARSEL - USYNLIG LASERSTRÅLING VED ÅBNING, N R
SIKKERHEDSBRYDERE ER UDE AF FUNKTION.
UNDG. UDSÆTTELSE FOR STRÅLING.

ADVARSEL - USYNLIG LASERSTRÅLING N R DEKSEL
ÅPNET. STIRR IKKE INN I STRÅLEN.
UNNG. EKSPONERING FOR STRÅLEN.

VARNING - OSYNLIG LASERSTRÅLING N R DENNA DEL
R ÅPPNAD OCH SPRÄNDRÄR URKOPPLAD.
BETRAKTA EJ STRÅLEN. STRÅLEN ÄR FARLIG.

VARO! - AVATTAESSA JA SUOJALUKITUS OHITETTAESSA
OLET ALTTIINA N KYM TT M LLE LASER-
S TEILYLLE L KATSO S TEESEEN.

注 意 - 严禁揭开此盖, 以免激光泄露灼伤

주 의 - 이 덮개를 열면 레이저광에 노출될 수 있으므로
주의하십시오.

1.2 Caution for safety

1.2.1 Toxic material

This product contains toxic materials that could cause illness if ingested.

- (1) If the LCD control panel is damaged it is possible for the liquid inside to leak. This liquid is toxic. Contact with the skin should be avoided, wash any splashes from eyes or skin immediately and contact your doctor. If the liquid gets into the mouth or is swallowed see a doctor immediately.
- (2) Please keep toner cartridges away from children. The toner powder contained in the toner cartridge may be harmful and if swallowed you should contact a doctor.

1.2.2 Electric Shock and Fire Safety Precautions

Failure to follow the following instructions could cause electric shock or potentially cause a fire.

- (1) Use only the correct voltage, failure to do so could damage the printer and potentially cause a fire cause an electric shock.
- (2) Use only the power cable supplied with the printer. Use of an incorrectly specified cable could cause the cable to overheat and potentially cause a fire.
- (3) Do not overload the power socket, this could lead to overheating of the cables inside the wall and could lead to a fire.
- (4) Do not allow water or other liquids to spill into the printer, this can cause electric shock. Do not allow paper clips, pins or other foreign objects to fall into the printer these could cause a short circuit leading to an electric shock or fire hazard..
- (5) Never touch the plugs on either end of the power cable with wet hands, this can cause electric shock. When servicing the printer remove the power plug from the wall socket.
- (6) Use caution when inserting or taking off the power plug. The power plug has to be inserted completely. If not, a fire will be caused due to poor contact. When taking off the power plug, grip the plug and remove it.
- (7) Take care of the power cable. Do not allow it to become twisted, bent sharply round corners or other wise damaged. Do not place objects on top of the power cable. If the power cable is damaged it could overheat and cause a fire or exposed cables could cause an electric shock. Replace a damaged power cable immediately, do not reuse or repair the damaged cable. Some chemicals can attack the coating on the power cable, weakening the cover or exposing cables causing fire and shock risks.
- (8) Ensure that the power sockets and plugs are not cracked or broken in any way. Any such defects should be repaired immediately. Take care not to cut or damage the power cable or plugs when moving the machine.
- (9) Use caution during thunder or lightening storms. Samsung recommend that this machine be disconnected from the power source when such weather conditions are expected. Do not touch the machine or the power cord if it is still connected to the wall socket in these weather conditions.
- (10) Avoid damp or dusty areas, install the printer in a clean well ventilated location. Do not position the machine near a humidifier. Damp and dust build up inside the machine can lead to overheating and cause a fire.
- (11) Do not position the printer in direct sunlight. This will cause the temperature inside the printer to rise possibly leading to the printer failing to work properly and in extreme conditions could lead to a fire.
- (12) Do not insert any metal objects into the machine through the ventilator fan or other part of the casing, it could make contact with a high voltage conductor inside the machine and cause an electric shock.

1.2.3 Handling Precautions

The following instructions are for your own personal safety, to avoid injury and so as not to damage the printer

- (1) Ensure the printer is installed on a level surface, capable of supporting its weight. Failure to do so could cause the printer to tip or fall.
- (2) printer contains many rollers, gears and fans. Take great care to ensure that you do not catch your fingers, hair or clothing in any of these rotating devices.
- (3) Do not place any small metal objects, containers of water, chemicals or other liquids close to the printer which if spilled could get into the machine and cause damage or a shock or fire hazard.
- (4) Do not install the machine in areas with high dust or moisture levels, beside on open window or close to a humidifier or heater. Damage could be cause to the printer in such areas.
- (5) Do not place candles, burning cigarettes, etc on the printer, These could cause a fire.

1.2.4 Assembly / Disassembly Precautions

Replace parts carefully, always use Samsung parts. Take care to note the exact location of parts and also cable routing before dismantling any part of the machine. Ensure all parts and cables are replaced correctly. Please carry out the following procedures before dismantling the printer or replacing any parts.

- (1) Check the contents of the machine memory and make a note of any user settings. These will be erased if the mainboard or network card is replaced.
- (2) Ensure that power is disconnected before servicing or replacing any electrical parts.
- (3) Disconnect printer interface cables and power cables.
- (4) Only use approved spare parts. Ensure that part number, product name, any voltage, current or temperature rating are correct.
- (5) When removing or re-fitting any parts do not use excessive force, especially when fitting screws into plastic.
- (6) Take care not to drop any small parts into the machine.
- (7) Handling of the Toner Cartridge
 - The OPC Drum can be irreparably damaged if it exposed to light.
Take care not to expose the OPC Drum either to direct sunlight or to fluorescent or incandescent room lighting. Exposure for as little as 5 mins can damage the surface's photoconductive properties and will result in print quality degradation. Take extra care when servicing the printer. Remove the OPC Drum and store it in a black bag or other lightproof container. Take care when working with the covers(especially the top cover) open as light is admitted to the OPC area and can damage the OPC Drum.
 - Take care not to scratch the green surface of OPC Drum Unit.
If the green surface of the Drum Cartridge is scratched or touched the print quality will be compromised.

1.2.5 Disregarding this warning may cause bodily injury

(1) Be careful with the high temperature part.

The fuser unit works at a high temperature. Use caution when working on the printer. Wait for the fuser to cool down before disassembly.

(2) Do not put finger or hair into the rotating parts.

Take care when using a printer. It contains many rotating parts. Ensure that fingers, hair, clothing etc. do not become caught in the mechanism as this could cause injury.

(3) When you move the printer.

This printer weighs 8.8kg including toner cartridge and cassette. Use safe lifting and handling techniques. Use the lifting handles located on each side of the machine. Back injury could be caused if you do not lift carefully.

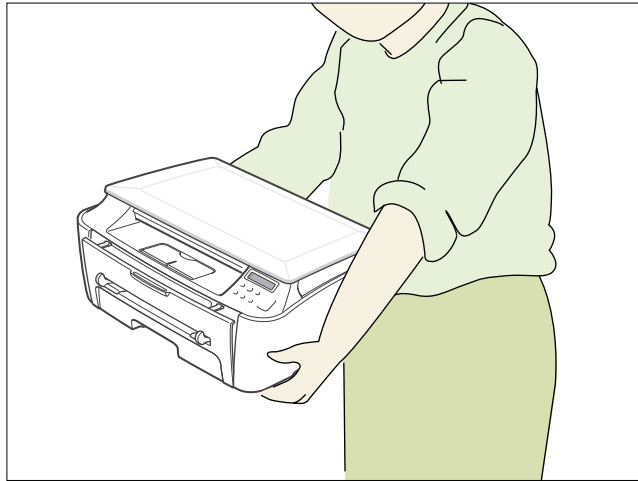

(4) Ensure the printer is installed safely.

The printer weighs 8.8Kg, ensure the printer is installed on a level surface, capable of supporting its weight. Failure to do so could cause the printer to tip or fall possibly causing personal injury or damaging the printer.

(5) Do not install the printer on a sloping or unstable surface. After installation, double check that the printer is stable.

1.3 ESD Precautions

Certain semiconductor devices can be easily damaged by static electricity. Such components are commonly called “Electrostatically Sensitive (ES) Devices”, or ESDs. Examples of typical ESDs are: integrated circuits, some field effect transistors, and semiconductor “chip” components.

The techniques outlined below should be followed to help reduce the incidence of component damage caused by static electricity.

Caution >>Be sure no power is applied to the chassis or circuit, and observe all other safety precautions.

1. Immediately before handling a semiconductor component or semiconductor-equipped assembly, drain off any electrostatic charge on your body by touching a known earth ground. Alternatively, employ a commercially available wrist strap device, which should be removed for your personal safety reasons prior to applying power to the unit under test.
2. After removing an electrical assembly equipped with ESDs, place the assembly on a conductive surface, such as aluminum or copper foil, or conductive foam, to prevent electrostatic charge buildup in the vicinity of the assembly.
3. Use only a grounded tip soldering iron to solder or desolder ESDs.
4. Use only an “anti-static” solder removal device. Some solder removal devices not classified as “anti-static” can generate electrical charges sufficient to damage ESDs.
5. Do not use Freon-propelled chemicals. When sprayed, these can generate electrical charges sufficient to damage ESDs.
6. Do not remove a replacement ESD from its protective packaging until immediately before installing it. Most replacement ESDs are packaged with all leads shorted together by conductive foam, aluminum foil, or a comparable conductive material.
7. Immediately before removing the protective shorting material from the leads of a replacement ESD, touch the protective material to the chassis or circuit assembly into which the device will be installed.
8. Maintain continuous electrical contact between the ESD and the assembly into which it will be installed, until completely plugged or soldered into the circuit.
9. Minimize bodily motions when handling unpackaged replacement ESDs. Normal motions, such as the brushing together of clothing fabric and lifting one’s foot from a carpeted floor, can generate static electricity sufficient to damage an ESD.

2. Reference Information

This chapter contains the tools list, list of abbreviations used in this manual, and a guide to the location space required when installing the printer. A definition of tests pages is also included.

2.1 Tool for Troubleshooting

The following tools are recommended for safe and smooth troubleshooting described in this service manual.

1

DVM(Digital Volt Meter)

Standard: Indicates more than 3 digits.

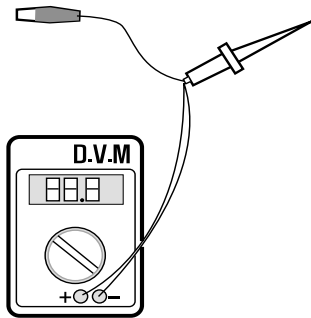

2

Driver

Standard : "-" type, "+" type (M3 long, M3 short, M2 long, M2 short).

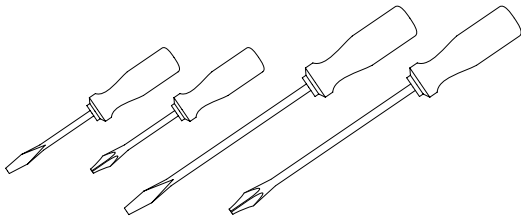

3

Tweezers

Standard : For general home use, small type.

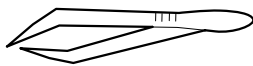

4

Cotton Swab

Standard : For general home use, for medical service.



5

Cleaning Equipments

Standard : An IPA(Isopropyl Alcohol)dry wipe tissue or a gentle neutral detergent and lint-free cloth.



6

Vacuum Cleaner

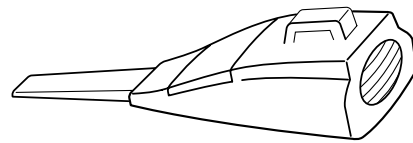

7

Spring Hook

Standard : For general use



8

Software(Driver) installation CD ROM

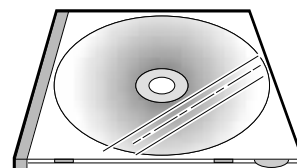

2.2 Acronyms and Abbreviations

The table in the below explains abbreviations used in this service manual.

The contents of this service manual are declared with abbreviations in many parts. Please refer to the table.

ADC	Analog-to-Digital-Conversion	FCOT	First Copy Out Time
AP	Access Point	FFC	FLexiable FLat Cable
AC	Alternating Current	LAN	local area network
ASIC	Application Specific Integrated Circuit	LBP	Laser Beam Printer
ASSY	Assembly	EPP	Enhanced Parallel Port
BIOS	Basic Input Output System	F/W	Firmware
BLDC Motor	Brushless DC Motor	FCF/FCT	First Cassette Feeder/First Cassette Tray
CIS	Contact Image Sensor	FISO	Front-In, Side-Out
CMOS	Complementary Metal Oxide Semiconductor	FPOT	First Print out Time
CN	Connector	GDI	Windows Graphic Device Interface
CON	Connector	GIF	Graphic Interchange Format
CPU	Central Processing Unit	GND	Ground
dB	Decibel	HBP	Host Based Printing
dBA	A-Weighted decibel	HDD	Hard Disk Drive
dBm	Decibel milliwatt	HTML	Hyper Text Transfer Protocol
DC	Direct Current	HV	High Voltage
DCU	Diagnostic Control Unit	HVPS	High Voltage Power Supply
DIMM	Dual In-line Memory Module	I/F	Interface
DPI	Dot Per Inch	I/O	Input and Output
DRAM	Dynamic Random Access Memory	lb	Pound(s)
DVM	Digital Voltmeter	IC	Integrated Circuit
ECP	Enhanced Capability Port	ICC	International Color Consortium
ECU	Engine Control Unit	IDE	Intelligent Drive Electronics or Integrated Drive Electronics
EEPROM	Electronically Erasable Programmable Read Only Memory	IEEE	Institute of Electrical and Electronics Engineers. Inc
EMI	Electro Magnetic Interference	IOT	Image Output Terminal (Color printer, Copier)
EP	Electro photographic	IPA	Isopropy Alcohol
EPP	Enhanced Parallel Port		

IPC	Inter Process Communication	RAM	Random Access Memory
IPM	Images Per Minute	ROM	Read Only Memory
LCD	Liquid Crystal Display	SCF/SCT	Second Cassette Feeder/Second Cassette Tray
LED	Light Emitting Diode	SMPS	Switching Mode Power Supply
LSU	Laser Scanning Unit	SPGP	Samsung Printer Graphic Processor
MB	Megabyte	SPL	Samsung Printer Language
MFP	Multi-Functional Product	Spool	Simultaneous Peripheral Operation Online
MHz	Megahertz	SURF	Surface Rapid Fusing
MPBF	Mean Prints Between Failure	SW	Switch
MPF/MPT	Multi Purpose Feeder/Multi Purpose Tray	sync	Synchronous or Synchronization
NIC	Network Interface Card	T1	ITB
NPC	Network Printer Card	T2	Transfer Roller
NVRAM	Nonvolatile Random Access Memory	TBD	To Be Determined
OPC	Organic Photo Conductor	TRC	Toner Reproduction Curve
PBA	Printed Board Assembly	TTM	Time to Market
PCL	Printer Command Language , Printer Control Language	PnP	Universal Plug and Play
PCI	Peripheral Component Interconnect by Intel 1992/6/22, is a local bus standard developed by Intel and introduced in April, 1993 : A60, B60 Pins	UMC	Unit Manufacturing Cost
PDF	Portable Document Format	URL	Uniform Resource Locator
PDL	Page Description Language	USB	Universal Serial Bus
Ping	Packet internet or Inter-Network Groper	VCCI	Voluntary Control Council for Interference Information Technology Equipment
PPD	Postscript Printer Discription	WECA Alliance	Wireless Ethernet Compatibility
PPM	Page Per Minute	Wi-Fi	Wireless Fidelity
PS	Post Script		
PTL	Pre-Transfer Lamp		
PWM	Pulse Width Moduration		
Q'ty	Quantity		
QCD	Quality, Cost, and Delivery		

2.3 Select a location for the printer

- Leave enough room to open the printer trays, covers, and allow for proper ventilation. (see diagram below)
- Provide the proper environment :
 - A firm, level surface
 - Away from the direct airflow of air conditioners, heaters, or ventilators
 - Free of extreme fluctuations of temperature, sunlight, or humidity
 - Clean, dry, and free of dust

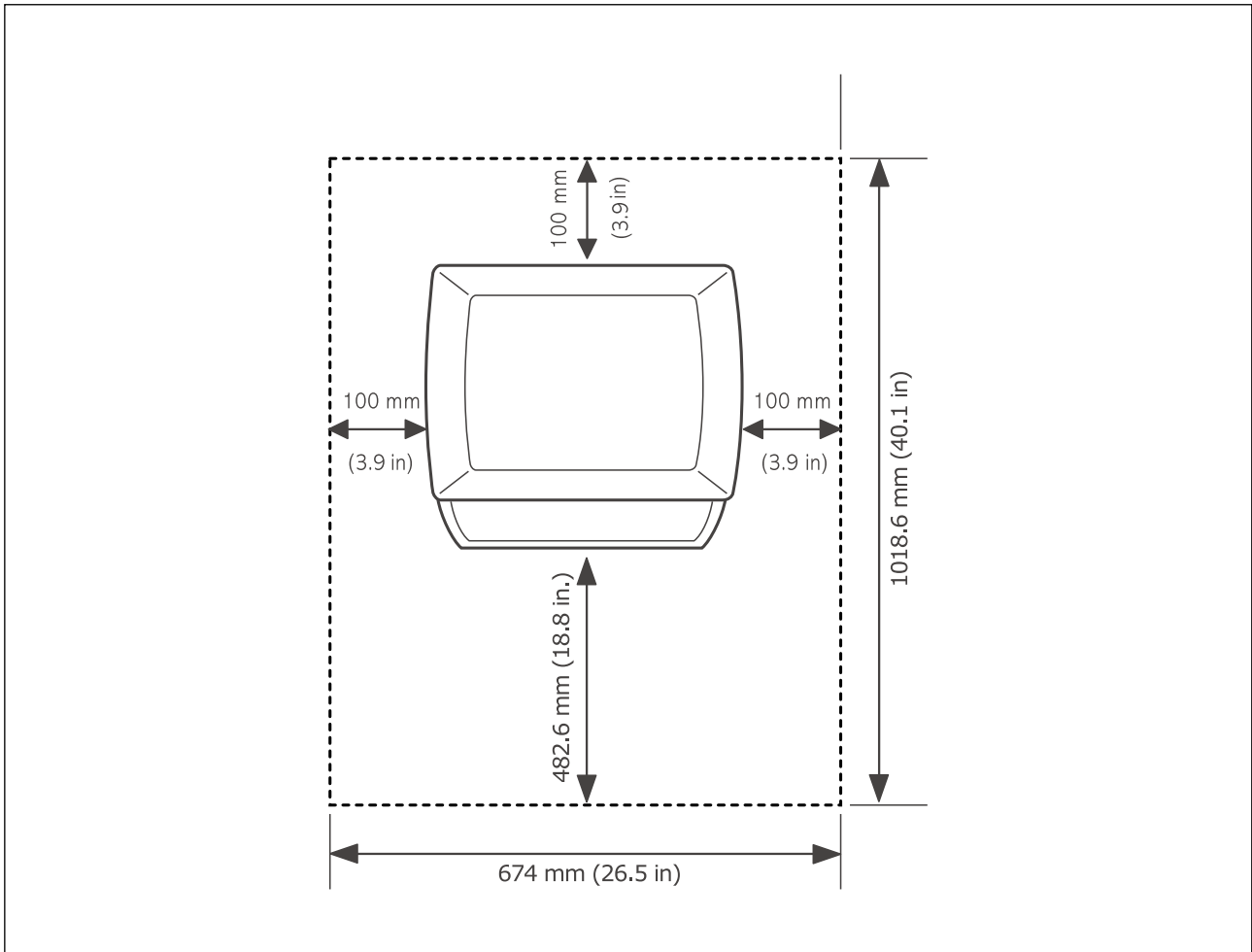

2.4 The Sample Pattern for the Test

The sample pattern shown in below is the standard pattern used in a factory.

The contents of the life span and the printing speed are measured with the pattern shown in below.

(The picture in the manual is 70% size of the actual A4 size.)

2.4.1 A4 5% Pattern

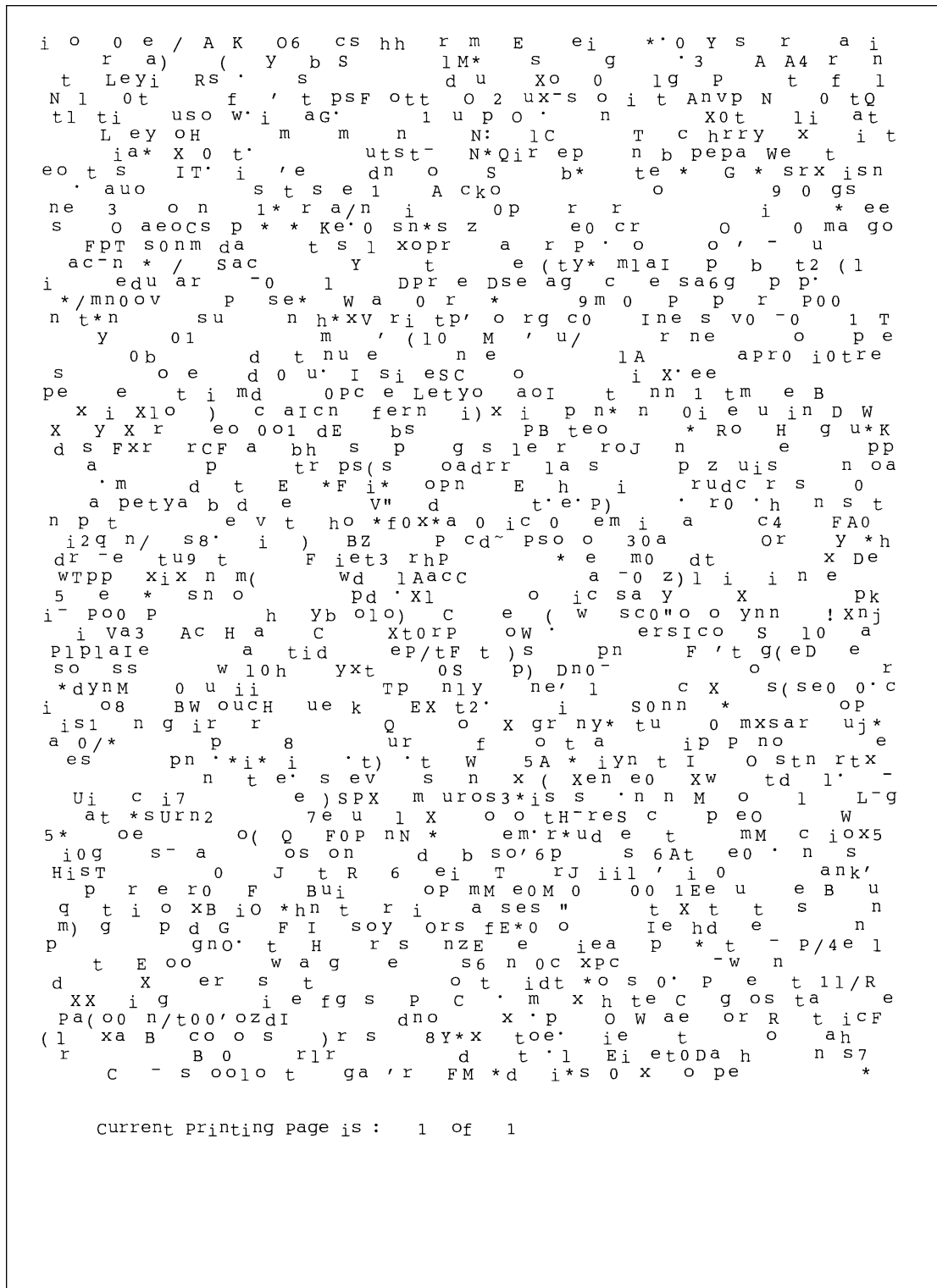

2.4.2 A4 2% Pattern

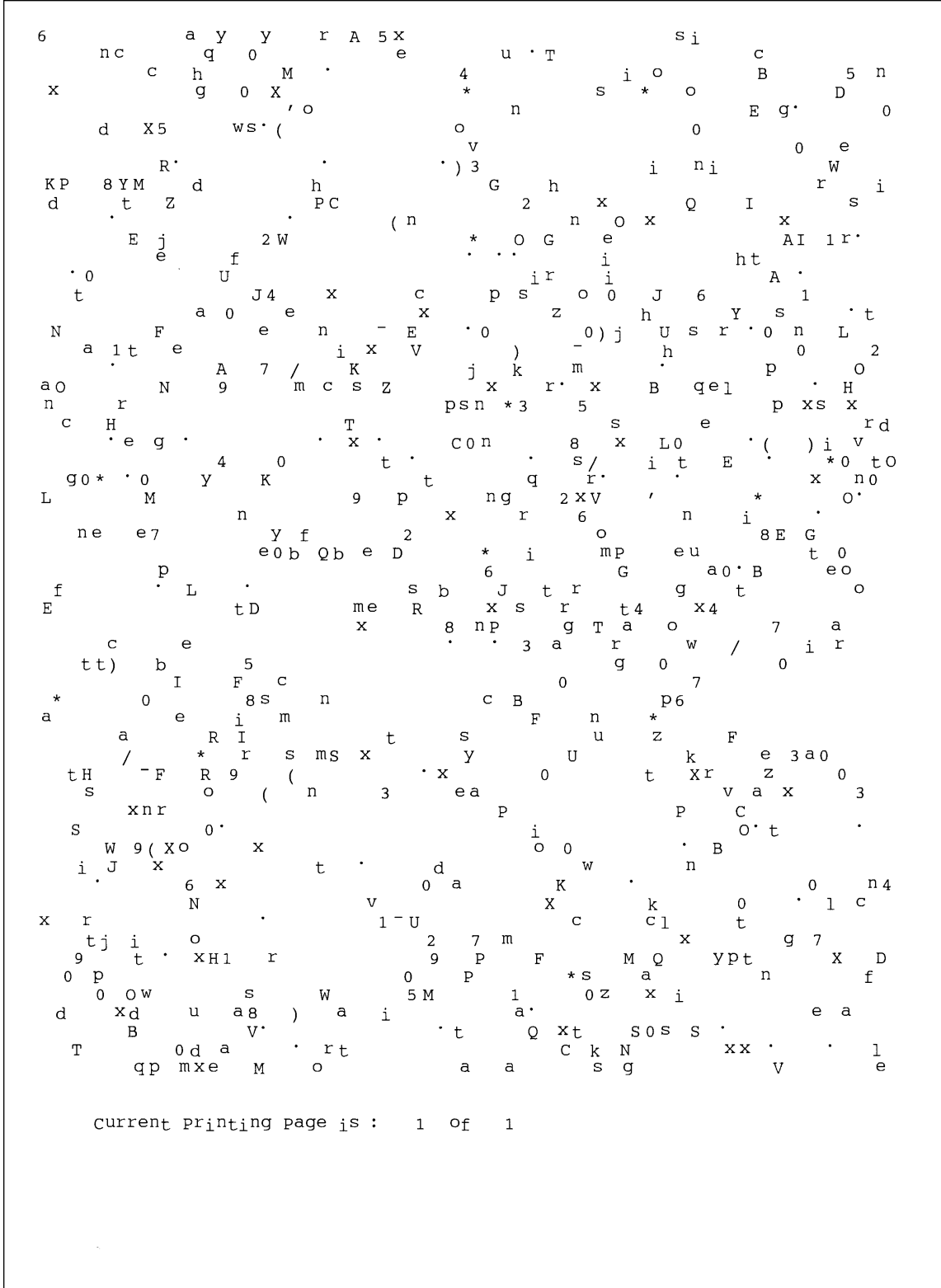

current printing page is : 1 of 1

2.4.3 A4 IDC 5% Patten

INTEROFFICE MEMORANDUM

TO: Cathy Scott
FROM: Lane Wolters
SUBJECT: The Typical Printed Page
DATE: 07/14/09

What does the typical laser printer document look like? Well, across the diverse business community it would be impossible to capture all aspects of printing style within a single page document. However, if attention is focused on the majority of printing volume, text and simple business graphics would stand out as the most prevalent output from laser printers. This

sample memo represents a reasonable example of the typical business document. This memo covers approximately 5% of a letter or A4-sized piece of paper. This number (5%) has historically been called the "average" page coverage by laser printer manufacturers. It may seem to the naked eye that there is much more than 5%, but in fact, alphanumeric characters rely on a large portion of white space for their composition.

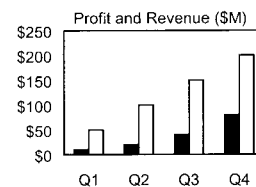

Mileage Chart

City	London	Los Angeles	New York	Tokyo
London	--	5456	3453	5975
Los Angeles	5456	--	2468	5451
New York	3453	2468	--	6736
Tokyo	5975	5451	6736	--

There are many factors that can influence the actual page coverage of a document as well as the page-yield of a toner cartridge. Testing parameters such as font size and style, internal printer settings, print environment, paper stock, sample size, job length and criteria for determining "end of life", can all influence how long a toner cartridge will last. The best competitive analysis of printer page yield should occur under similar conditions using industry standards for the variables listed above.

MEMO



3. Specifications

Specifications are correct at the time of printing. Product specifications are subject to change without notice. See below for product specifications.

3.1 General Specifications

Items		SCX-4100	Remarks
General	Major Features	Copier,Print,Scan	
	Size (W*D*H)	16.6"x15.8" x9.4" (422x400x239mm)	
	Net Weight(Inc. Toner Cartridge)	0.69 Kg	
	Net Weight(exc. Toner Cartridge)	8.89 Kg	
	Gross Weight(with package)	12.04 Kg	
	LCD	16*2 Char	No BackLite
	I/O Interface	USB1.1 & IEEE1284	
Power	Printing Operation	300 Wh	
Consumption	Sleep Mode	Energy Star Compliant	
	Power Switch	Yes	
Noise	Operating	49 dBA	
	Standby	38 dBA	
Warm Up Time	from Cold Status	Less than 42 seconds	
Machine Life	Max. Monthly Volume (Duty Cycle)	Print	10,000pages
		Scan	2,000pages
	Average Monthly Print Volume	500 Pages	
	Machine Life	5 years, 100000 Pages Whichever comes first.	
Approval		Class B	
Device Memory		8MB	
Internal N/W Option		N/A	
Page Counter		Yes	
Print Configuration Sheet		Yes	

3.2 Print Specification

Items		SCX-4100	Remarks	
PRINT	Print Speed	15ppm/Ltr, 14ppm/A4		
	Print Method	Laser		
	Print Language	SPL		
	Power Save	Yes(5/10/15/30/45min.)		
	Resolution	Normal	600 x 600 dpi	
		RET	No	
	Toner Save	Yes	LCD Only (Toner Save On/Off Setting method is in the Menu).	
	Memory	8MB		
	FPOT	From Stand by	Approx. 12 seconds	
		From Cold Status	Less than 54 seconds	
	Duplex Print	N.A		
Printable Area	208 x 273 mm (Letter)			
Halftone(Gray Scale)	256 levels			

3.3 Scan Specification

Items		SCX-4100	Remarks	
SCAN	Scan Method	Color CIS		
	Scan Speed through Platen	Lineart, Halftone	72 sec	
		Gray	72 sec	
		Color 75dpi/300dpi	40sec/150 sec	
	Resolution	Optical	600*600dpi	
		Enhanced	4800dpi*4800dpi (USB) 2400dpi*2400dpi(Parallel)	
	Halftone	256level		
	Scan Size	Max. Document Width	Max.216mm(8.5")	
		Effective Scan Width	Max 208mm(8.2inch)	
	Scan-to	E-mail, Image, OCR, WEB Through PC	"through PC --> means "from SmarThru4 application".	
	Scan Depth	Color	24 bit	
Mono		1bit for Lineart, Halftone, 8 Bit for Gray scale		

3.4 Copy Specification

Items		SCX-4100	Remarks	
COPY	Copy Quality Selection or Original Image type selection Mode	Text Text/Photo Photo	600x300dpi 600x300dpi 600x600dpi for Platen	
	FCOT	Stand by	Approx. 12 seconds	
		From Cold Status	Less than 54 seconds	
	Copy Speed / Letter	SDMC at all mode	15cpm/Ltr. 14cpm/A4	SDMC: Single Document Multiple Copy
	Resolution	Scan:600*600dpi Print:600*600dpi		
	Zoom Range		50% to 200%	
	Multi Copy		1~99	
	Preset		Yes	
	Darkness Control		3 level	Light, Normal, Dark
	Copy Mode(=Original Type)		Text, Text/Photo, Photo	
	Collation Copy		N/A	
	Auto return to default mode		Yes(after 1 minute)	Time can be changeable; 15,30,60,180sec, Off
	Changeable Default mode		Darkness, Original Type, Reduce/Enlarge, No. of Copies,	
	Special Copy	2-up copy		Yes(Platen only)
		Collation Copy		N/A
AutoFit Copy			Yes(Platen only)	
2 Sides in 1 pg			Yes(Platen only)	* Copy 2-side printed original document into one page(ex. ID Card Copy)
Clone			Yes(Platen only)	
Poster			Yes(Platen only)	

3.5 Paper Handling Specification

Items		SCX-4100	Remarks	
Paper Handling	Capacity(20lbs)	Main Tray	250sheets	
		Bypass(MP Tray)	Single Sheet	
	Optional Cassette	No		
	Output Capacity		Face Down: 50Sheets/20lb Face Up: 1Sheet	
	Output Control		Face down/Face up	
	Paper Size	Main Tray	Legal,A4,Letter, Folio, Executive, B5, A5, A6	
		Bypass	Bypass:Envelope6 3/4, 7 3/4,#9, #10,DL,C5,B5	With main tray paper
	Paper Weight	Main Tray	16~24 lb.	
		Bypass	16~43 lb.	
	Paper Path	Standard output	Bottom to Top Front (FIFO)	
		Straight Through	Face up, Single Sheet	
	Paper Size	Max	216 x 356mm(8.5"x14")	
		Min	76 x 127mm(3"x5")	
Compatibility	DOS	No		

3.6 Other Specification

Items		SCX-4100	Remarks	
Software	WHQL	Win 3.x	No	
		Win 95	Yes	
		Win 98&WinME	Yes	
		Win NT 4.0	Yes	
		Win 2000	Yes	
		Win XP	Yes	
		Mac	Yes	Mac Printer Only
		Linux	Yes	Print, Scan
		Printer	Yes	Printer driver only for WinXP
	WIA	Scanner	No	
	Driver	Printer	SPL	
	Package	TWAIN	Yes	
		WIA	No	
		RCP	Yes	Remote Control Panel, Only for upgrade FW
PC-FAX		No	Only available through PC	
		Offset BOx		
Package and POP	POP	Yes		
	Quick Reference guide (include Setup Guide and Function Guide)	Yes		
Accessory	Owner's manual		Yes(Electronic)	
	S/W CD ROM		1 CD for User Manual, Smar Thru 4, Print Driver, Scan Driver, RCP	
	Toner Cartridge		1 EA	
	Power Cable		1 EA	L-shape power cable
	Telephone Jack		No	
	Printer Cable		No	China,Korea : USB Russia : Parallel cable
	Type		One Piece	
Consumables	How to install		Front door open and front loading	
	Toner		Life	Initial 1Kpages running 3Kpages
	Toner Count	Level Sensor	No	
		Software Count	No	

MEMO



4. Summary of Product

This chapter describes the functions and operating principles of the main component.

4.1 Printer Components

4.1.1 Front View

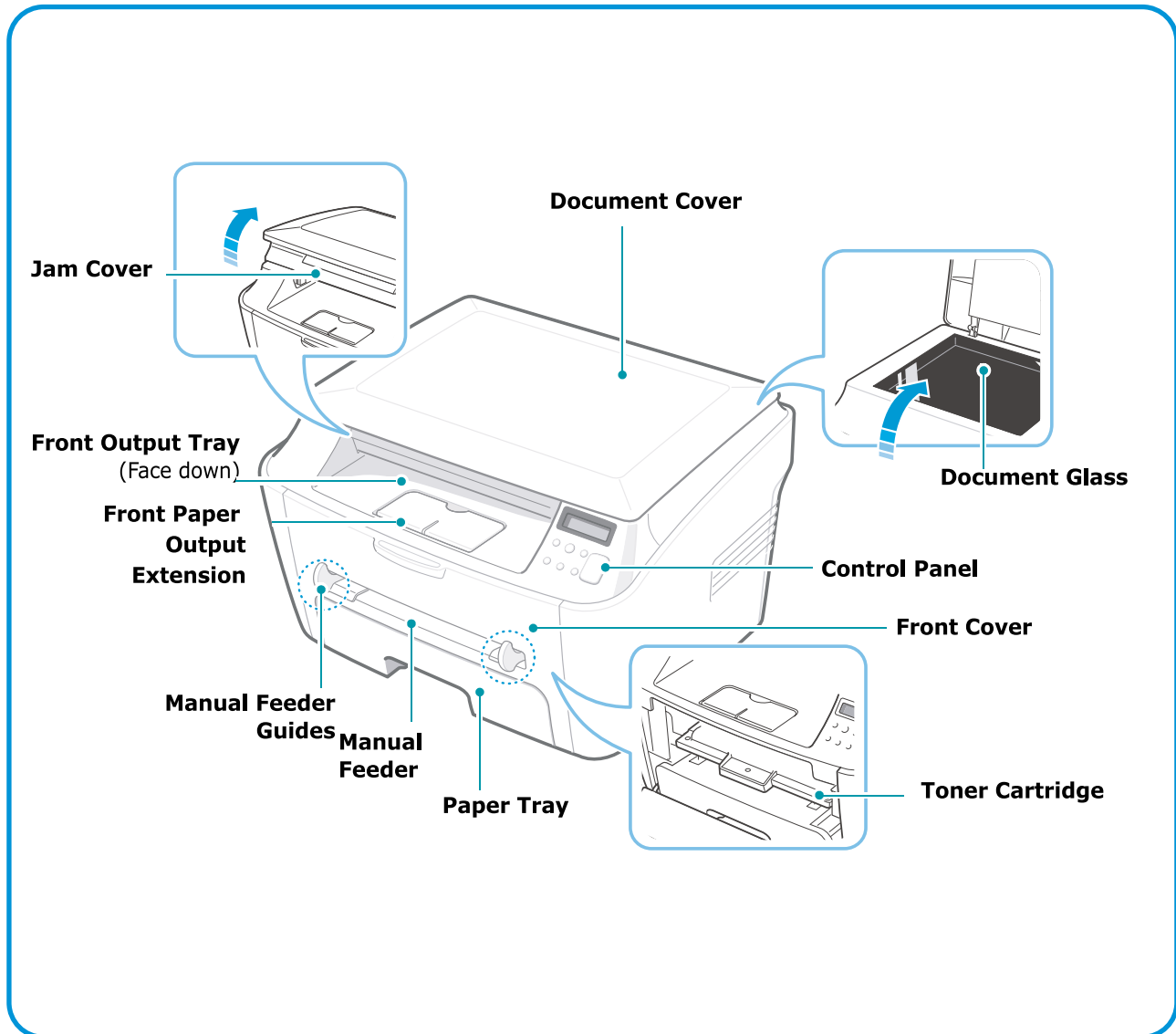



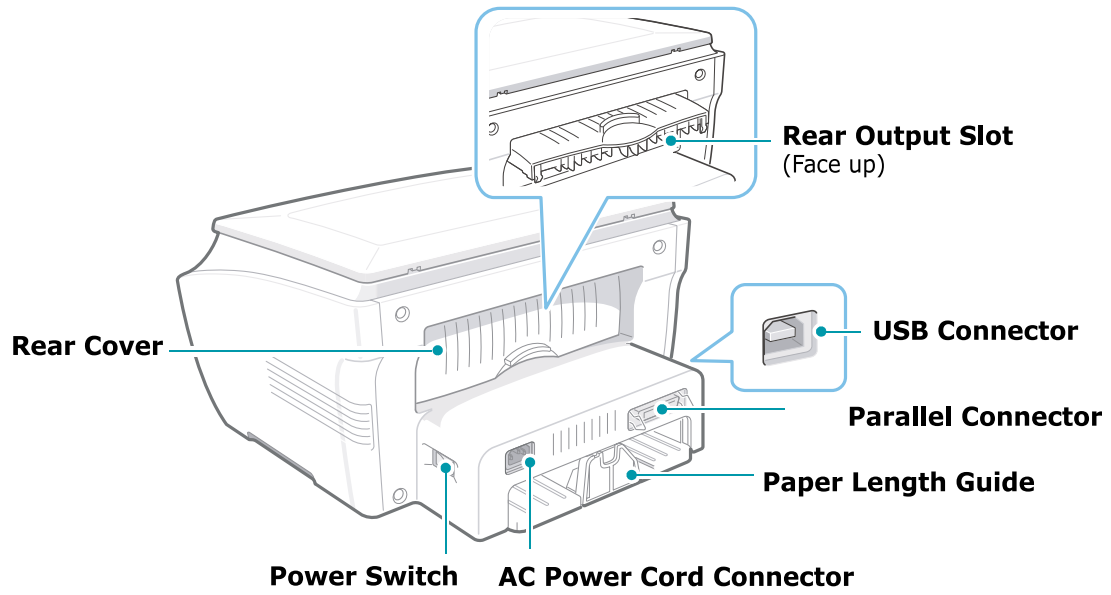

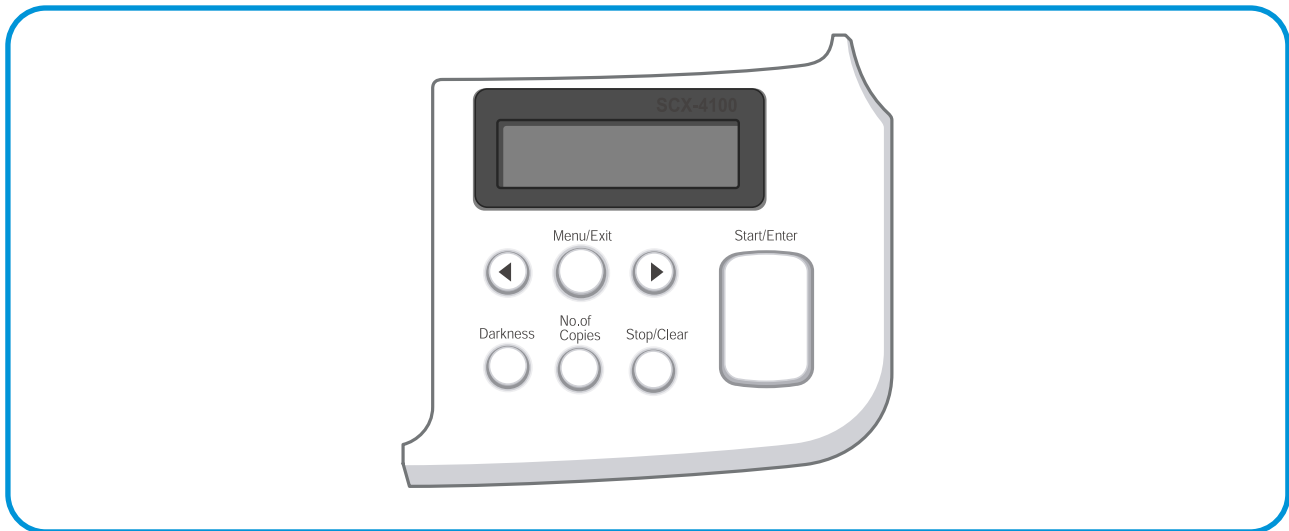

4.1.2 Rear View



4.1.3 Control Panel



1 C O P Y	Darkness 	Adjusts the brightness of the documents for the current copy job.
	No. of Copies 	Selects the number of copies.
2		Displays the current status and prompts during an operation.
3		Scrolls through the options available for the selected menu item.
	Menu/Exit 	Enters Menu mode and scrolls through the menus available and sends you back to Standby mode.
4	Stop/Clear 	Stops an operation at any time. In Standby mode, clears/cancels the copy options, such as the darkness and the number of copies.
5	Start/Enter 	Confirms the selection on the display and starts a job.

4.2 System Layout

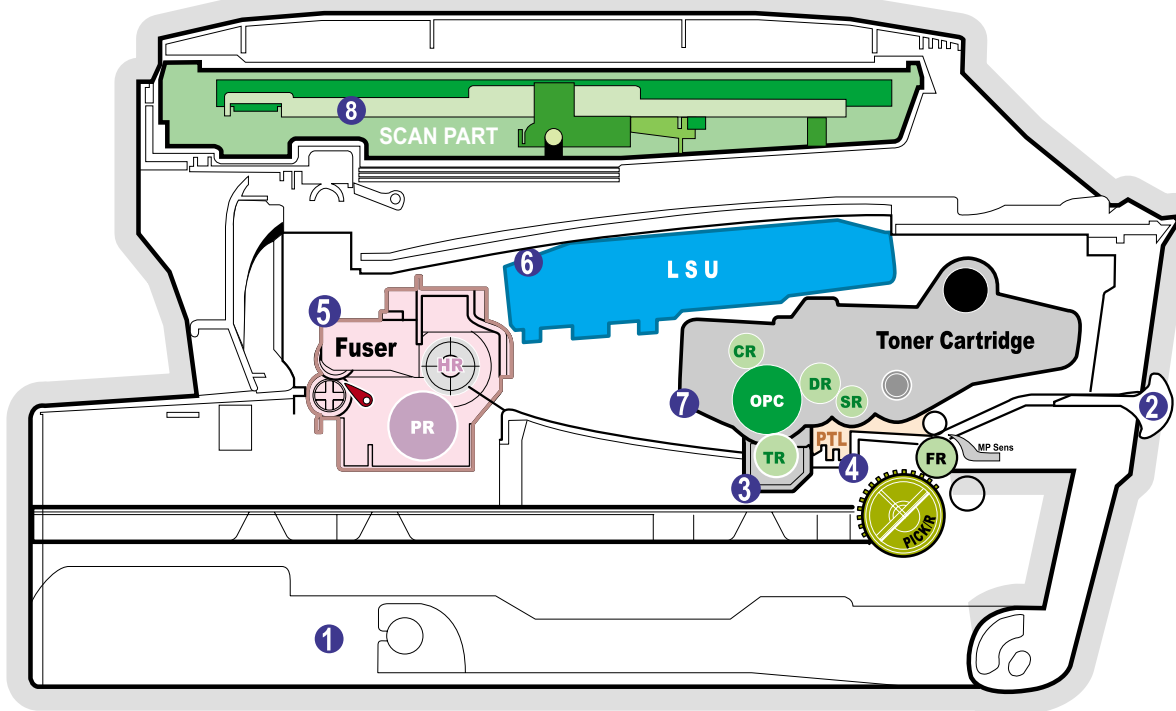

- | | |
|--------------------------|------------------------|
| ① Cassette | ⑤ Fuser |
| ② Manual Feeder | ⑥ LSU(Laser Scan Unit) |
| ③ Transfer Roller | ⑦ Toner Cartridge |
| ④ PTL(Pre-Transfer-Lamp) | ⑧ Scan Unit |

4.2.1 Paper Feed Mechanism

The printer has a universal cassette which automatically loads paper and a manual feed which supplies paper single sheet at a time. The cassette has a friction pad which separates paper to ensure single sheet feeding, and it has a sensor, which checks when the paper tray is empty.

- Feeding Method: Universal Cassette Type
- Feeding Standard: Center Loading
- Feeding Capacity: Cassette-250 sheets (75g/m² , 20lb paper standard)
Manual 1 sheet (Paper, OHP, Envelop, etc.)
- Paper detecting sensor: Photo sensor
- Paper size sensor: None

4.2.2 Transfer Ass'y

This consists of the PTL (pre-transfer lamp) and the Transfer Roller. The PTL shines a light onto the OPC drum. This lowers the charge on the drum's surface and improves transfer efficiency.

The transfer roller transfers toner from the OPC drum surface to the paper.

- Life expectancy: Over 60,000 sheets (at 15~30°C)

4.2.3 Drive Ass'y

A gear driven power unit. The motor supplies power to the paper feed unit, the fuser unit, and the toner cartridge.

4.2.4 Fixing Part(Fuser)

There are two types of fuser unit:

Q-PID type, developed by Samsung, and only used on 220V Domestic models

Heat Lamp type used on 220V Export models and all 110V models.

The Heat Lamp type fuser consists of the Heat Lamp, Heat Roller, Pressure Roller, Thermistor, and Thermostat. It fixes toner to the paper using pressure and heat to complete the printing job.

4.2.4.1 Heat Lamp power cut-off (Thermostat)

The thermostat is a temperature sensing device, which cuts off the power to the heat lamp to prevent overheating fire when the heat lamp or heat roller overheats.

4.2.4.2 Temperature Detecting Sensor (Thermistor)

The Thermistor detects the surface temperature of the heat roller, this information is sent to the main processor which uses this information to regulate the temperature of the heat roller.

4.2.4.3 Heat Roller

The surface of the Heat Roller is heated by the Heat Lamp. As the paper passes between the Heat and Pressure rollers the toner is melted and fixed permanently to the paper. The surface of the roller is coated with Teflon. This ensures that toner does not adhere to the roller surface.

4.2.4.4 Pressure roller

The Pressure Roller mounted under the heat roller, it is made of a silicon resin, and the surface of the roller is tubed with Teflon. This ensures that toner does not adhere to the roller surface.

4.2.4.5 Safety Relevant Facts

- To prevent overheating
 - 1st protection device: Hardware cuts off when overheated
 - 2nd protection device: Software cuts off when overheated
 - 3rd protection device: Thermostat cuts off mains power to the lamp.
- Safety device
 - Fuser power is cut off when the front cover is opened
 - LSU power is cut off when the front cover is opened
 - The temperature of the fuser cover's surface is maintained at less than 80°C to protect the user and a caution label is attached where the customer can see it easily when the rear cover is opened.

4.2.5 Scanner Unit

• Scan Image Controller

1. Scan Line Time : 1.67ms
2. Scan Resolution : Color : Max 600DPI
3. Scan Width : 216mm
4. Function
 - White Shading Correction
 - Gamma Correction
 - CIS Interface
 - 256 Gray Scale

• CIS Driver Circuit

- CIS Clock : 4.16MHz
- Voltage Reference : 1.1V
- CIS Line Time : 1.67ms/Line x 3Color(600dpi)

• Scan Motor Driver Circuit

- Motor Driver : SIA403A
- Used Volt : 24V DC

4.2.6 LSU (Laser Scanner Unit)

This is the core of the laser printer. It converts the video data received from the computer into an electrostatic latent image on the surface of the OPC drum. This is achieved by controlling the laser beam and exposing the surface of the OPC drum to the laser light. A rotating polygon mirror reflects the laser light onto the OPC and each side of the mirror is one scan line. The OPC drum turns as the paper feeds to scan the image down the page.

The /HSYNC signal is created when the laser beam from LSU reaches the end of the polygon mirror and this signal is sent to the controller. The controller detects the /HSYNC signal to adjust the vertical line of the image on paper. In other words after the /HSYNC signal is detected the image data is sent to the LSU to adjust the left margin on the paper.

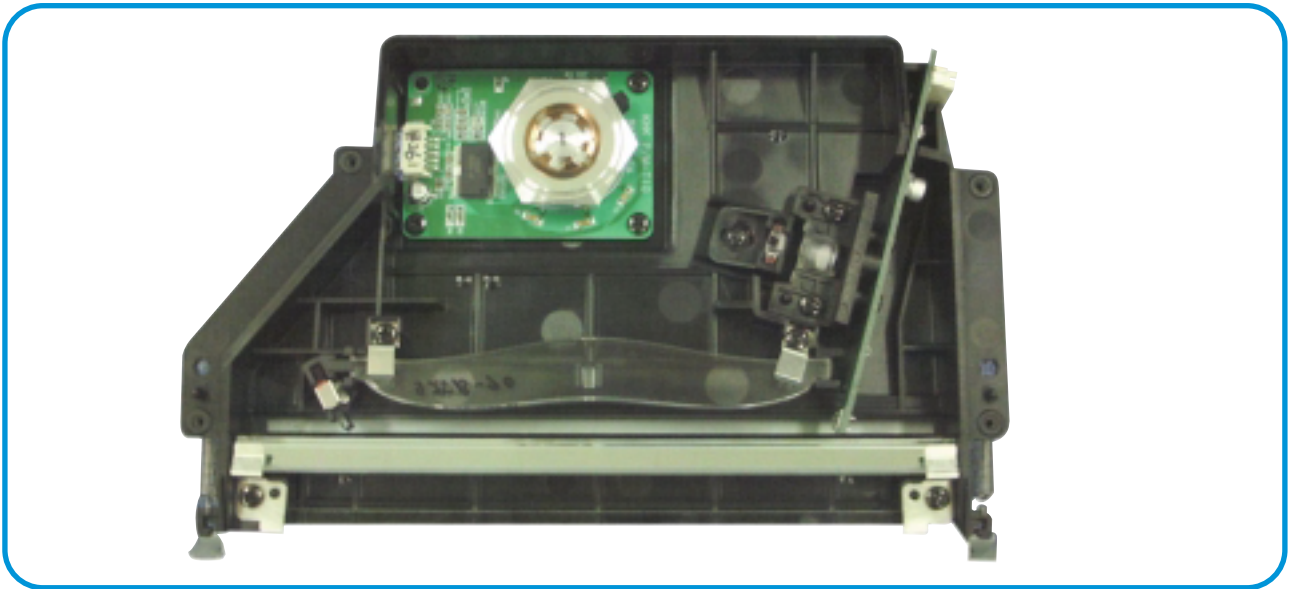

4.2.7 Toner Cartridge

The toner cartridge is an integral unit containing the OPC unit and toner unit. The OPC unit consists of the OPC drum and charging roller, and the toner cartridge unit consists of the toner, supply roller, developing roller, and blade (Doctor blade)

- Developing Method: Non magnetic 1 element contacting method
- Toner: Non magnetic 1 element shatter type toner
- The life span of toner: 3,000 sheets (IDC Pattern/A4 standard)
- Toner remaining amount detecting sensor: No
- OPC Cleaning: Electrostatic process
- Management of waste toner: Electro static process (Cleanerless Type)
- OPC Drum protecting Shutter: No
- Classifying device for toner cartridge: ID is classified by interruption of the frame channel

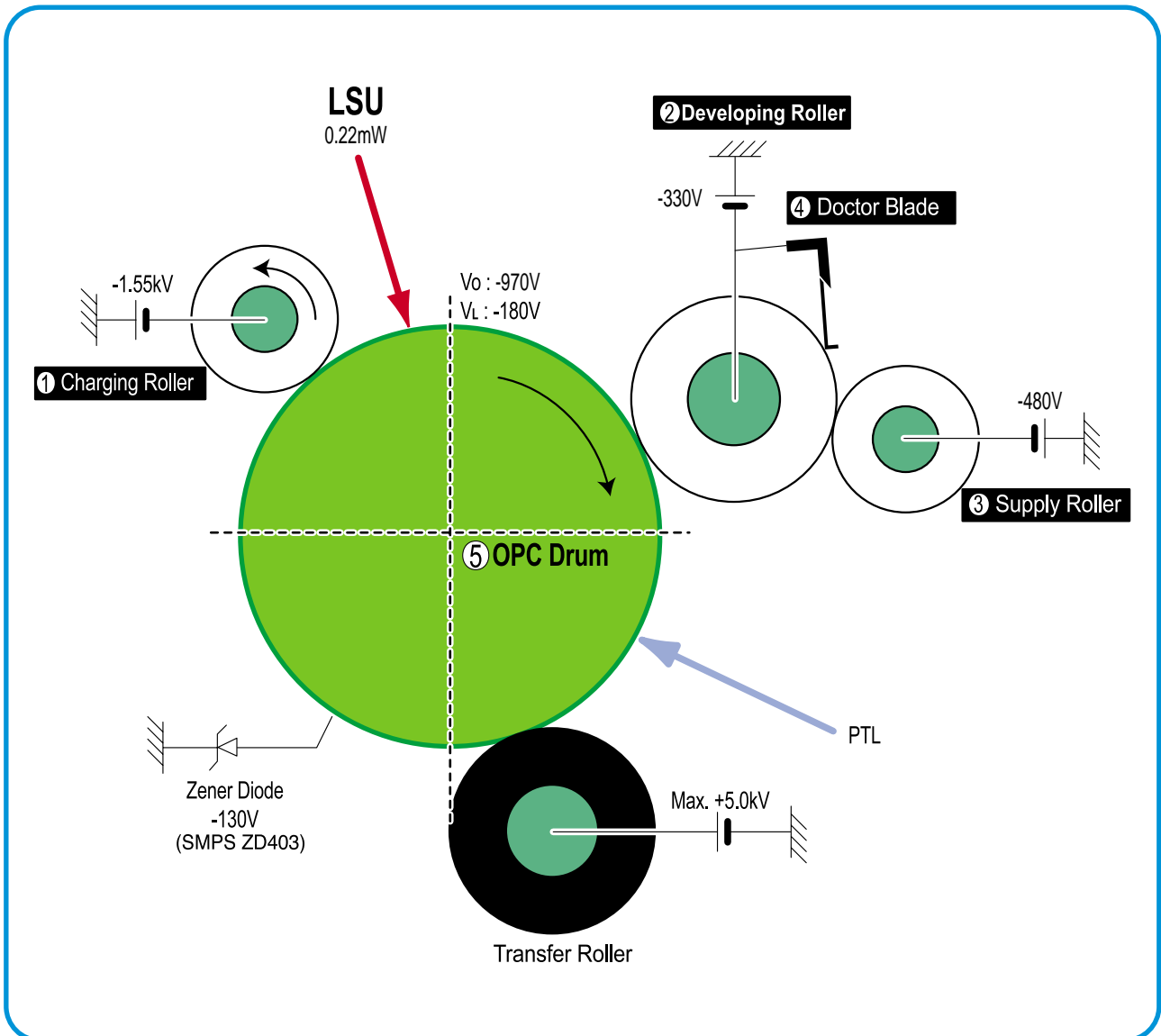

4.3 Main PBA

The Engine Board and Controller Board have been integrated into a single PBA. This consists of the CPU, printer scanner and line control functions. The CPU functions as the bus controller, I/O handler, motor driver and PC interface. The main board sends the Current Image Video data to the LSU and manages the Electrophotographic printing process. Circuits on the PBA drive include the main motor (paper feed, cartridge, fuser), clutch driver, pre-transfer lamp driver, heat-lamp driver, CIS driver, scan motor driver and fan driver. The signals from the paper feed jam sensor and paper empty sensor are inputted to the main board from the power supply PBA.

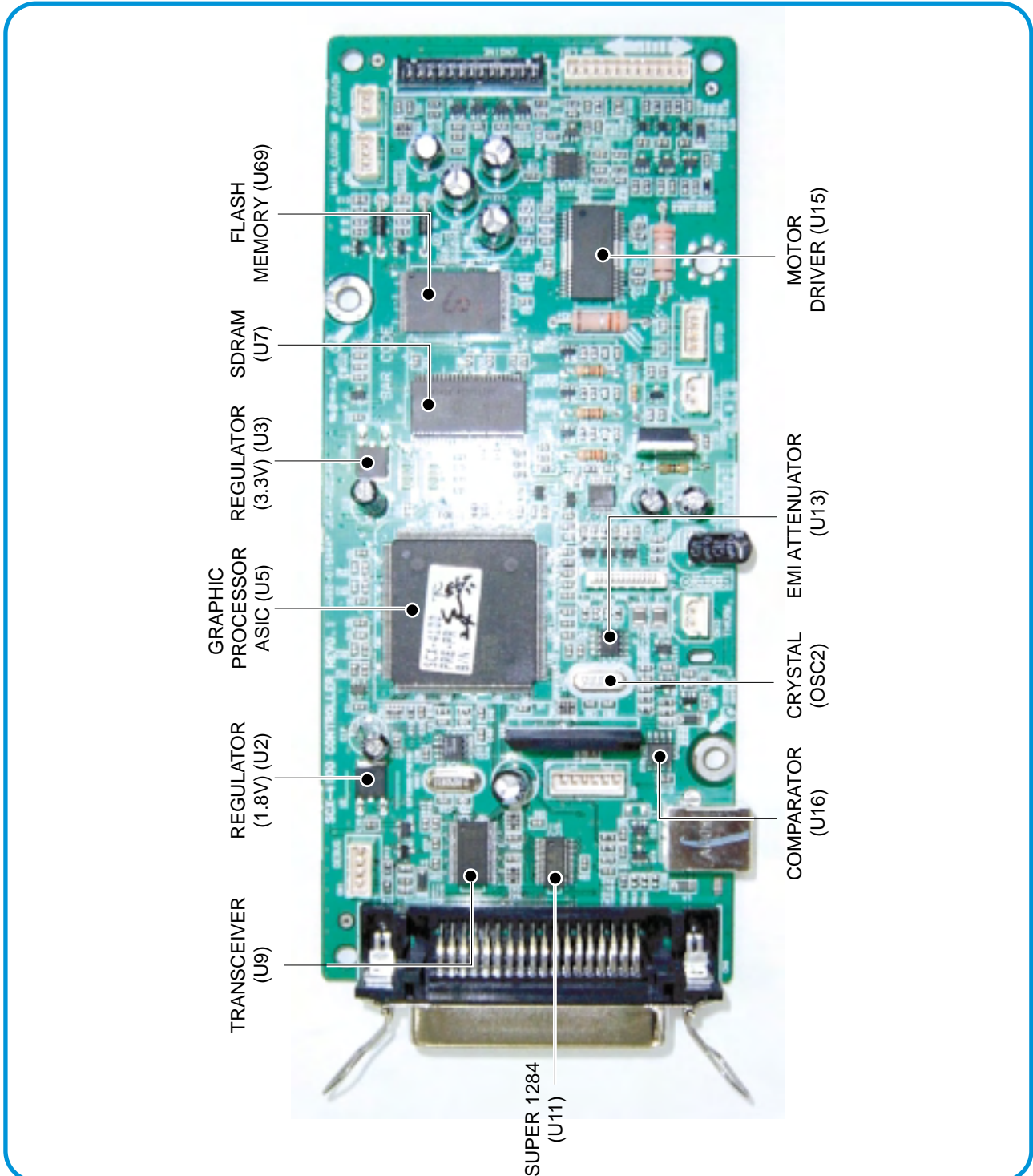

4.3.1 ASIC (Chorus2)

The Chorus2 (16Bit RISC Processor) ASIC is the main processor controlling the whole system. It controls all of the printing and scanning functions using a system program stored in flash memory.

•Main function block

- Completely Integrated System for Embedded Applications,
- 16/32 Bit Risc Architecture, Efficient and Powerful ARM7TDMI CPU
- LSU Interface Module for Interfacing PVC with LSU
- 5 Channel General Purpose DMA Controller for High Speed I/O
- Dual Memory Bus Architecture
- Operating frequency : 66MHz
- Operating power : 1.8V(internal), 3.3V(external)

4.3.2 Flash Memory

This stores the system program. Firmware upgrade is achieved by downloading from the new image using the PC Interface.

- Capacity : 1M Byte
- Access Time : 70 nsec

4.3.3 SDRAM

This is used as a buffer, system working memory area, etc. while printing and scanning.

- Capacity :

SCX-4100
8 M byte

- Access Time : 15 nsec

4.3.4 Sensor input circuit

1) Paper Empty Sensing

The Paper Empty sensor (Photo Interrupter) on the SMPS/HVPS PBA is monitored by the CPU. When the cassette is empty the printer displays a message on the LCD panel.

2) MP Sensing

Presence of paper in the MP tray is detected by operation of the MP Sensor (Photo Interrupter) on the SMPS/HVPS PBA. The CPU monitors this signal to recognize paper in the MP, and paper is fed from MP if there is paper present.

3) Paper Feeding, Toner Cartridge Sensing

When paper passes the actuator on the feed sensor, it is detected by the Photo interrupter.

Signal (nP_FEED, PIN 186) monitored by the CPU and this signal starts the process of creating the image after certain delay time. If the feed sensor is not detected within 1 sec. after paper is fed, a paper Jam0 occurs. (Displayed on the LCD panel).

When a toner cartridge is inserted it also operates the Paper Feed sensor. A message is displayed on the LCD if no cartridge is detected.

4) Paper Exit Sensing

This detects that paper exits cleanly from the set using an exit sensor on the engine board and actuator on the frame. The monitors signal (P_EXIT, PIN 84) and detects the on/off time of the exit sensor and if jam status is detected then JAM2 is displayed on the LCD panel.

5) Cover Open Sensing

The Cover open sensor actuator is located on the front cover and the sensor is in the main frame.

When the front cover is open the +24V and +5V supplies to the DC fan, solenoid, main motor, polygon motor part of LSU, HVPS and LSU Laser diode are cut off. The CPU monitors signal (COVER_OPEN, GPIO_11) to recognize when the cover is open.

6) DC FAN / SOLENOID Driver

It is driven by a transistor and controlled by signal (FAN, GPIO_7; Main Clutch Solenoid:PIN 185,MP Clutch Solenoid: PIN 184) bit of the CPU.

When it is high the fan is activated by turning on the TR, and it is off when the sleep mode is selected. There are three solenoids and these are driven by the Paper Pick-up, Regi and MP signals. The diode protects the driving TR from the Back-EMF pulse which is generated when the solenoid is de-energized.

7) Motor Driver

The motor driving circuit is activated when the Driver IC is enabled. An AN44060 (Motor driver IC) is used in this case. The resistance R_s value of sensing and the voltage value of the V reference can be changed by the motor driving voltage value.

4.4 SMPS & HVPS

The SMPS and HVPS are on one integrated board.

The SMPS supplies the DC power to the system. It takes either 110V or 220V and outputs the +5V and 24V supplies to the main and other PBAs.

The HVPS creates the high voltage of THV/MHV/Supply/Dev and supplies it to the toner cartridge. The CPU is used to modify some of these voltage settings to provide the ideal voltages to create the image.

The HVPS part uses the 24V and outputs the high voltage for THV/MHV/BIAS and the outputted high voltage is supplied to the toner, OPC cartridge and transfer roller.

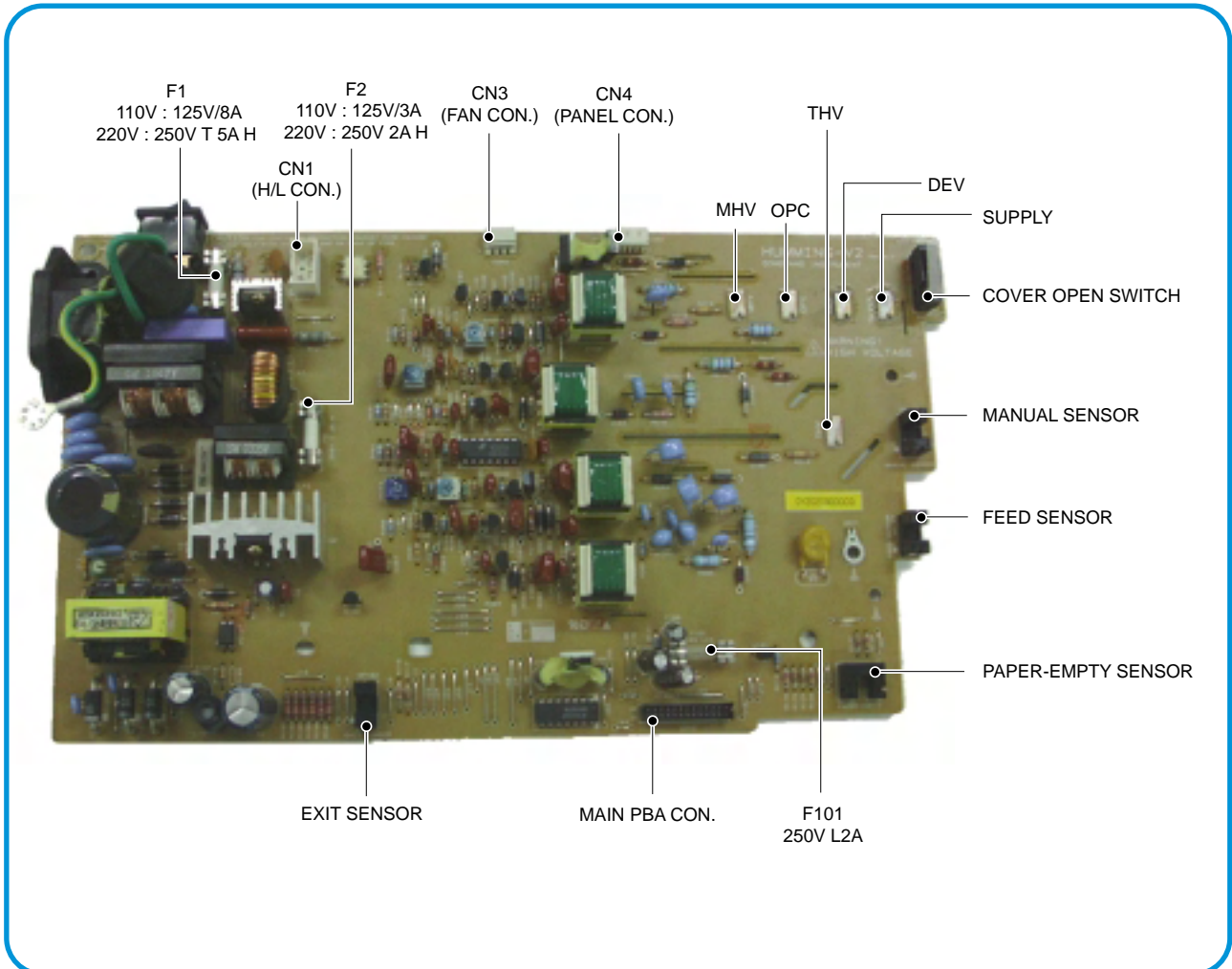

4.4.1 HVPS(High Voltage Power Supply)

1) Transfer High Voltage (THV+)

- Function : It is this voltage that transfers toner from the OPC Drum to the paper.
- Output voltage : Maximum +5000V \pm 5% (no load, variable duty cycle)
- Error : IF THV (+) is not present, low density printing occurs due to toner on the OPC Drum not being transferred to the paper. It is possible that waste toner over-flow can occur if this condition persists. Ghost images may appear which repeat at 76mm intervals.

2) Charge Voltage (MHV)

- Function : It is this voltage that charges the surface of the OPC to -900V ~ -1000V.
- Output voltage : -1300V ~ -1800V DC \pm 50V
- Error : IF MHV is not present toner then since the OPC drum surface has no charge toner is attracted to the whole OPC surface. A black page is printed out when this happens.

3)Cleaning Voltage (THV-)

- Function : It removes toner contamination from the rear side of the paper by sending (-) polarity to the transfer roller forcing toner to transfer back to the to OPC drum.
- Output Voltage : -1000VDC, +300V/-150V
- Error : Smudges and toner contamination on the reverse side of the printed page.

4) Developing Voltage (DEV)

- Function: It is this voltage that develops toner with on to the section of the OPC drum surface exposed by the LSU (Laser Scanning Unit).
- * When printing the exposed voltage on the OPC is -180V, unexposed is -970V, and the exposing voltage on the DEV is -330V. Therefore toner with (-) polarity is developed onto an exposed section of the OPC.
- Output voltage: -200V ~ 600V DC \pm 20V
- Error: a) If DEV is GND, print density gets extremely low.
b) When DEV is floating due to poor connection between the frame and cartridge contacts etc., print density gets extremely high.

5) Supply Voltage (SUP)

- Function: It is this voltage that supplies toner to the developing roller.
- Output voltage: : -350V ~ -750V DC \pm 50V (Use ZENER)
- Error: a) When SUP is GND print density gets extremely low.
b) If SUP is floating due to poor connection between the frame and cartridge contacts etc. density gets extremely low such that it is hard to see toner with the eyes

6) OPC Ground ZENER Voltage

- Function: It is this voltage that prevents image contamination under low temperature and low humidity environment conditions.
- When a set prints without an output voltage, -130V DC \pm 15V is maintained on OPC ground. (-130V ZENER diode is connected to OPC ground)
- Error type: a) When the ZENER diode is - 0V there is no serious image problem in general environment, but in low temperature and low humidity environments it is possible that contamination can occur on the entire image
b) When the ZENER diode is disconnected a blank page is printed out. (It is the same when a ZENER diode is disconnected from OPC ground.)

4.4.2 SMPS (Switching Mode Power Supply)

This is the power source for the whole system. It is an independent module so that it is possible to use it for common use. It is mounted at the bottom of the set.

It consists of the SMPS section, which supplies the DC power to drive the system, and the AC heater control part, which supplies the power to the fuser. The SMPS has four output channels (+5V, +3.3V, +3.3VS and +24VS). There are three kinds of power, 120V exclusive (America), 220V exclusive (Europe), and 220V for China (nations with unstable power supply).

1) AC Input

- Inputting rated voltage : AC 220V ~ 240V AC 100~127V
- Inputting voltage fluctuating range : AC 198V ~ 264V AC 90V ~ 135V
- Rated frequency : 50/60 Hz
- Frequency fluctuating range : 47 ~ 63 Hz
- Inputting Current : Under 4.0Arms/2.0Arms (when heat lamp is off)

2) Rated Power Output

NO	Item	CH1	CH2	CH3	Remark
1	Channel name	+5V	+24V	+24.0VS	
2	Connector Pin	CON 4 5V PIN: 3, 4, 23 GND PIN: 5, 6	CON 4 24V PIN : 14 GND PIN: 8, 9, 10	CON 4 24V PIN: 11, 12 GND : 8, 9, 10	
3	Rated Output Voltage	+5V ± 5% (4.75 ~ 5.25V)	+24V - 10/15% (21.6 ~ 27.46V)	+24VS - 10/15% (21.6 ~ 27.46V)	
4	Max. Output current	1.0 A	0.5A	1.0 A	
5	Peak Loading voltage	1.5 A	1.0A	1.5 A	1ms
6	Ripple noise voltage	Under 150m Vp-p	Under 500m Vp-p	Under 500m Vp-p	
7	Maximum output	5.0W	12W	24W	

3) Consumption Power

NO	Item	CH1 (+5V)	CH2 (+24V)	CH3 (+24VS)	System
1	Stand-By	0.2 A	0.07A	0.07 A	AVG : 60 Wh
2	PRINTING	1.0 A	0.5A	1.0 A	AVG : 300 Wh
3	Sleep-Mode	0.2A	0.02A	0.03A	AVG : 10 Wh

4) Length of Power Cord : 1830 ± 50mm

5) Power Switch : Fitted

6) Feature

- Insulation resistance : over 50M Ω (at DC500V)
- Insulation retest pressure : Must be no problem within 1min. (at 1500Vzc, 10mA)
- Leakage voltage : under 3.5mA
- Running voltage : under 40A peak (at 25°C, Cold start) Under 60A peak (in other conditions)
- Rise Time : Within 2Sec
- Fall Time : Over 20ms
- Surge : Ring Wave 6KV-500A (Normal, Common)

7) Environment Condition

- Operating temperature range : 0°C ~ 40°C
- Storage temperature range : -25°C ~ 85°C
- Storage humidity range : 30% ~ 90% RH
- Operating atmospheric pressure range : 1

8) EMI Requirement : CISPR ,FCC, CE, MIC, C-Tick,**9) Safty Requirement**

- IEC950 UL1950, CSA950, C-UL,Semko,iK,CB, CCC(CCIB),GOST, EPA,

4.4.3 Fuser AC Power Control

The Fuser (HEAT LAMP) is heated using AC power. The AC power is controlled by a Triac (THY1), a semiconductor switch. 'On/Off control' is achieved when the gate of the Triac is turned on/off by a Photo triac (PC1), this is an insulting part.

In the other words the AC control part is a passive circuit. It turns the heat lamp on/off by taking a signal from the engine control section. When the 'HEATER ON' signal is activated by the engine the LED of PC1 (Photo Triac) flashes. The flashing light causes the Triac (PC1) to switch and a voltage is supplied to the gate of Triac THY1. As a result AC current flows in the heat lamp, and heat is produced. On the other hand, when the signal is off, PC1 is off, the voltage is cut off at the gate of Triac THY1, this Triac is therefore off, and thus the heat lamp is turned off.

1) Triac (THY1) feature

- 12A,600V SWITCHING

2) Phototriac Coupler (PC3)

- Turn On If Current : 15mA ~ 50mA(Design: 16mA)
- High Repetive Peak Off State Voltage : Min 600V

4.5 Engine F/W

4.5.1 Feeding

If feeding from the cassette the drive of the pickup roller is controlled by controlling the pick-up solenoid. The on/off of the solenoid is controlled by controlling the general output port or the external output port. If feeding from the manual feeder the set decides to feed the paper according to the operation of the manual sensor, and by driving the main motor, insert the paper in front of the feed sensor. When paper moves the occurrence of a paper jam is judged as below.

4.5.1.1 Jam 0 – Jam in Feed area

- After a page was picked up, paper did not enter the unit due to a paper misfeed.
- After a page was picked up, paper entered but it did not reach the feed sensor in certain time due to slip, etc.
- After a page was picked up, if the feed sensor is not on try to pick up again. After retrying if the feed sensor is still not on after certain time, it is Jam 0.
 - this indicates that the leading edge of the paper doesn't pass the feed sensor within a certain time.
- Even though the paper reaches the feed sensor, the feed sensor does not turn on.
 - this indicates that the leading edge of the paper already passed the feed sensor or that the sensor is faulty.

4.5.1.2 Jam 1 – Jam inside the print engine

- After the leading edge of the paper passes the feed sensor, the trailing edge of the paper does not pass the feed sensor within certain time. (During this time the feed sensor cannot be Off)
- After the leading edge of the paper passes the feed sensor, the paper does not reach the exit sensor within a certain time. (The exit sensor cannot be On during this time)
 - There is already paper between the feed sensor and the exit sensor.

4.5.1.3 Jam 2 – Jam in the Exit area

- After the trailing edge of the paper passes the feed sensor the trailing edge of the paper does not pass the exit sensor within certain time.

4.5.2 Drive

The main motor drives the paper feed, developing unit and the Fuser It is driven by software which controls the acceleration, constant speed and deceleration profiles. The Motor is managed with an AN44060 driver IC and controlled by step and enable signals from the CPU.

4.5.3 Transfer

The charging voltage, developing voltage and the transfer voltage are controlled by PWM (Pulse Width Modulation). Each output voltage is changeable according to the PWM duty cycle. The transfer voltage used when the paper passes the transfer roller is decided by environment recognition. The resistance value of the transfer roller changes due to the surrounding environment in the room or within the set, this change in resistance in turn changes the value of the voltage due to loading. This voltage is fed back into the set through the A/D converter. Based on this fed back value the PWM cycle is changed to maintain the required transfer voltage Page 4-10 has a different chip number Which is correct

4.5.4 Fusing

The temperature of the heat roller's surface is detected according to the resistance value of the thermistor. The thermistor resistance is measured using the A/D converter and thus the CPU can determine the temperature of the heat roller. The AC power is controlled by comparing the target temperature to the value from the thermistor. If the value from the thermistor is out of the controlling range while controlling the fusing process, the error stated in the table occurs. (For the domestic model, the Q-PID method has been applied.)

• Heat Lamp Method

Error	Description	LCD Displat
Open heat error	When warming up, it has been lower than 68°C over 28 seconds	All open heat error are blinking
Lower heat error	<ul style="list-style-type: none"> • Standby: It has been lower than 80°C over 10 seconds • Printing: <ul style="list-style-type: none"> - 2 consecutive pages: it has been lower than 145°C over 4 seconds. - 3 consecutive page; it has been 25°C lower than the fixed fusing temperature over 4 seconds. 	All low heat error are blinking
Over heat error	It have been higher than 220°C over 3 seconds	All over heat error are blinking

4.5.5 LSU

The LSU consists of the LD (Laser Diode) and the polygon motor control. When the printing signal occurs, the LD is turned on and the polygon motor is enabled. When the light sensor detects the beam, Hsync occurs. When the polygon motor speed becomes a normal, LReady occurs. If these two conditions are satisfied, the status bit of the LSU controller register becomes 1 and the LSU is judged to be ready. If the two conditions are not satisfied, the error shown in the table below occurs.

Error	Description
Polygon motor error	When the polygon motor's speed doesn't reach operating speed
Hsync error	The polygon motor's speed is normal, but the Hsync signal is not created.

MEMO



5. Disassembly and Reassembly

5.1 General Precautions on Disassembly

When you disassemble and reassemble components, you must use extreme caution. The close proximity of cables to moving parts makes proper routing a must.

If components are removed, any cables disturbed by the procedure must be restored as close as possible to their original positions. Before removing any component from the machine, note the cable routing that will be affected.

Whenever servicing the machine, you must perform as follows:

1. Check to verify that documents are not stored in memory.
2. Be sure to remove the toner cartridge before you disassemble parts.
3. Unplug the power cord.
4. Use a flat and clean surface.
5. Replace only with authorized components.
6. Do not force plastic-material components.
7. Make sure all components are in their proper position.

Releasing Plastic Latches

Many of the parts are held in place with plastic latches. The latches break easily; release them carefully.

To remove such parts, press the hook end of the latch away from the part to which it is latched.

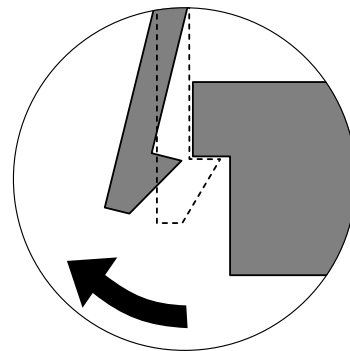

5.2 Front and Rear Cover Units

1. Take the Cassette out of the printer.

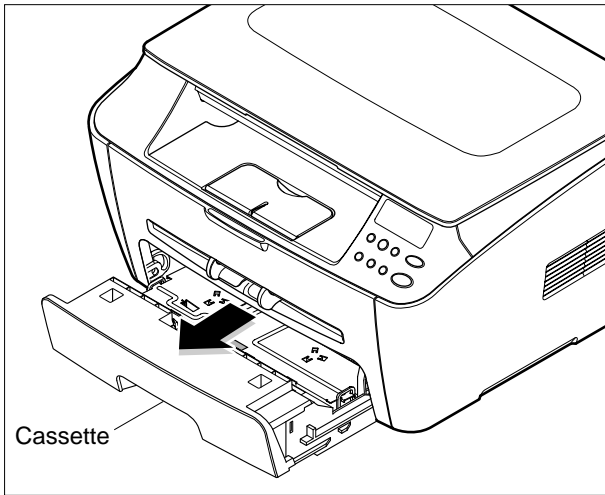

2. Remove the Front Cover in the direction of arrow.

3. Remove the 4 screws securing the Rear Cover and remove it, as shown below.

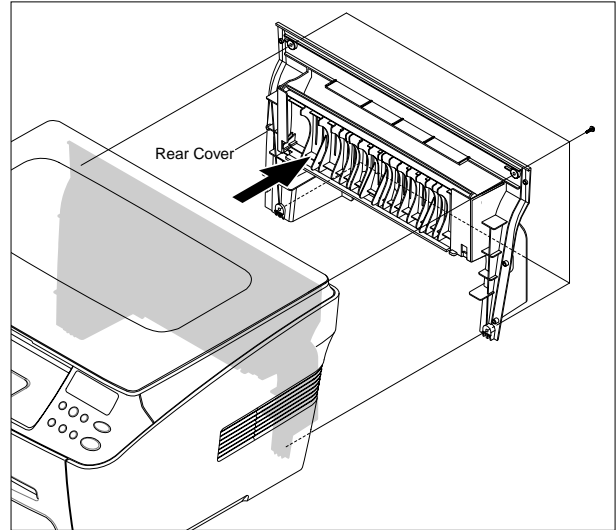

5.3 Side Covers

1. Before you remove the Side Cover (Left Cover, Right Cover), you should remove:
 - Rear Cover (see page 5-2)
 - Front Cover (see page 5-2)
2. Remove 1 screw at the front of the unit. Unclip the right cover along the top edge and remove it from the Frame Assembly.

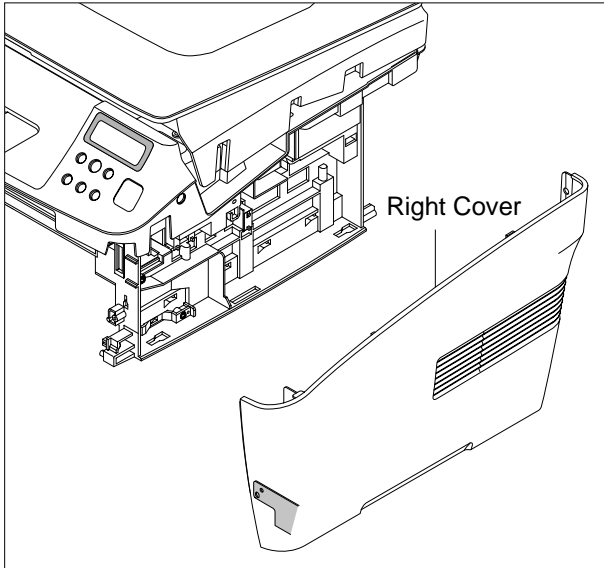

3. Remove 1 screw at the front of the unit. Unclip the right cover along the top edge and remove it from the Frame Assembly.

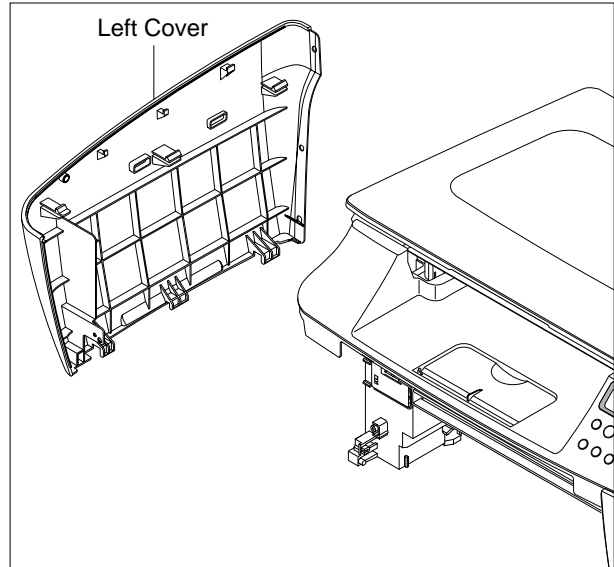

5.4 Scanner Ass'y

< Caution >

1. Before disassembling the Scanner Ass'y first lift it carefully at the front edge. The support lever will automatically raise into position.

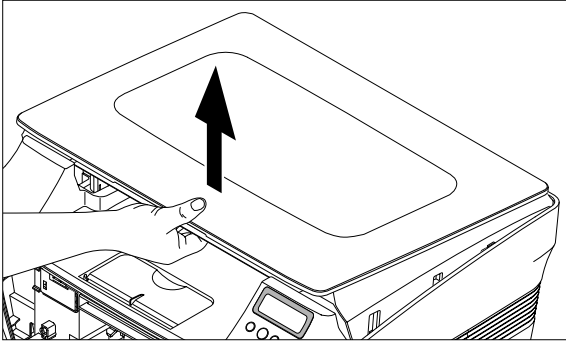

2. Take care not to trap your fingers or hand in the mechanism.

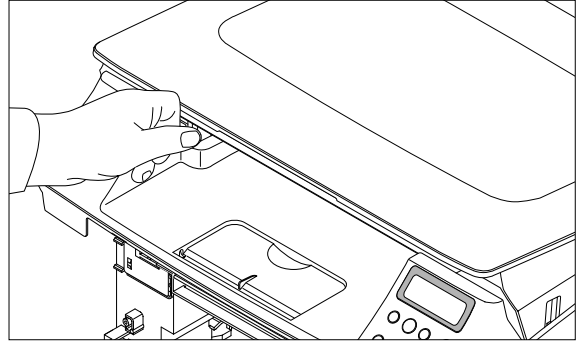

5.4.1 Remove Scanner Ass'y

1. Before you remove the Scanner Ass'y, you should remove:
 - Rear Cover (see page 5-2)
 - Side Cover(Left Cover, Right Cover)(see page 5-3)
2. Remove the 2 connectors from the main PBA and release the ground wire from the Motor Drive Ass'y as shown below.

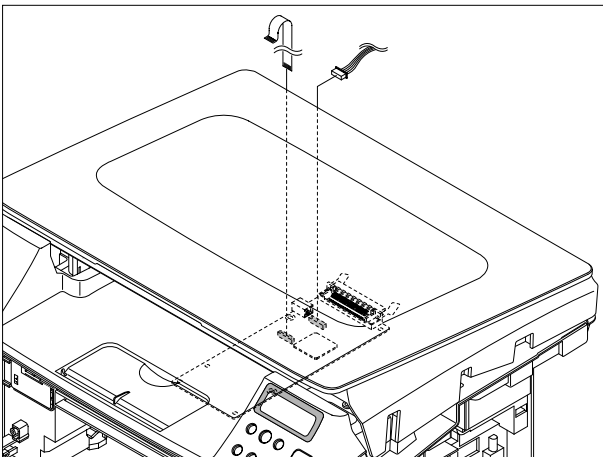

3. Carefully lift the Scanner Ass'y from the base taking care to thread the cables through the frame.

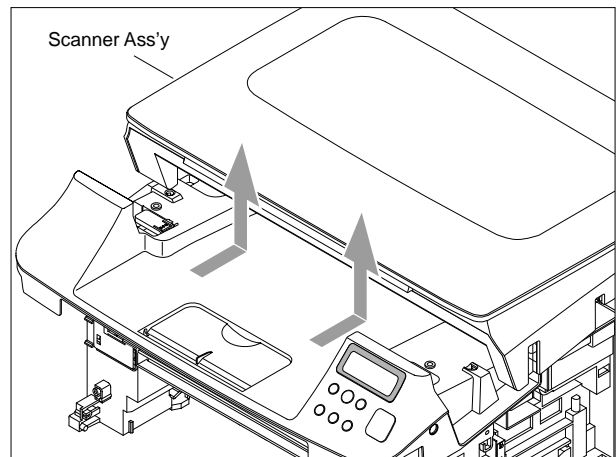

5.4.2 Dismantle Scanner Ass'y

< Caution >

1. Before disassembling the scanner module remove the 2 plastic spacers from each end of the scanner module.

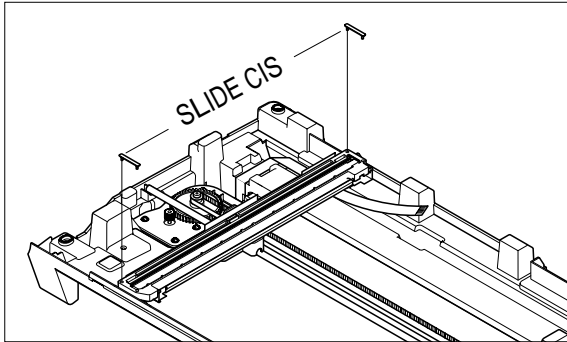

1. Lift the Platen Cover upward and remove it.

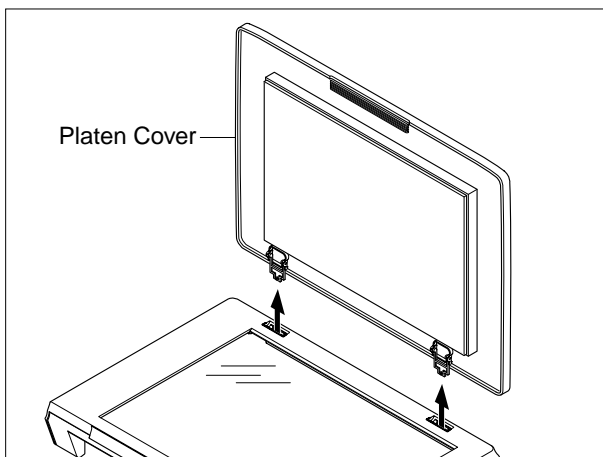

3. Remove the CCD Cable, as shown below.

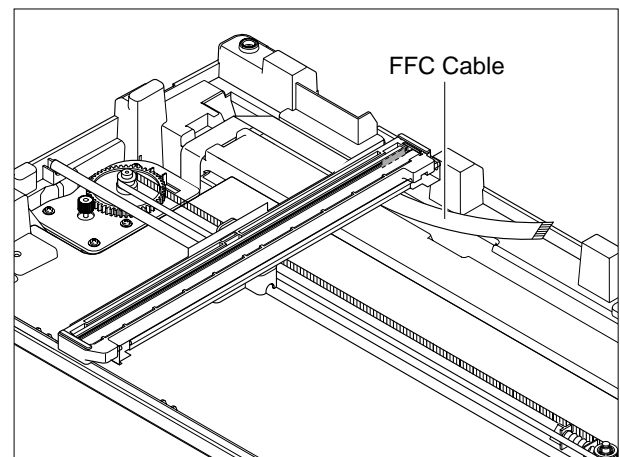

2. Release 8 clips (2 per side) securing the scanner upper frame to the scanner lower frame and remove the upper frame

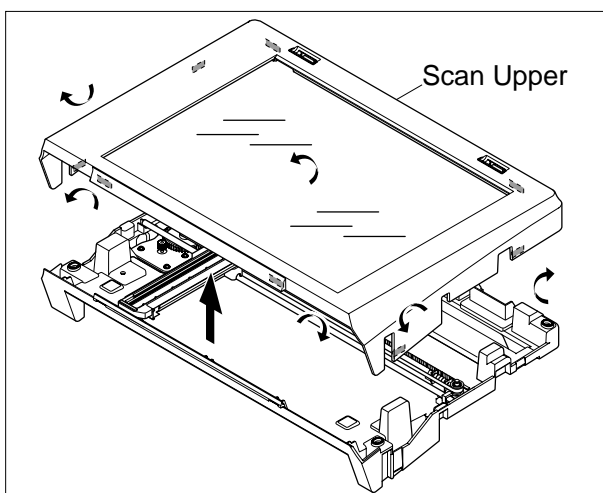

4. Pull up the CCD Shaft and take out the Scanner Module.

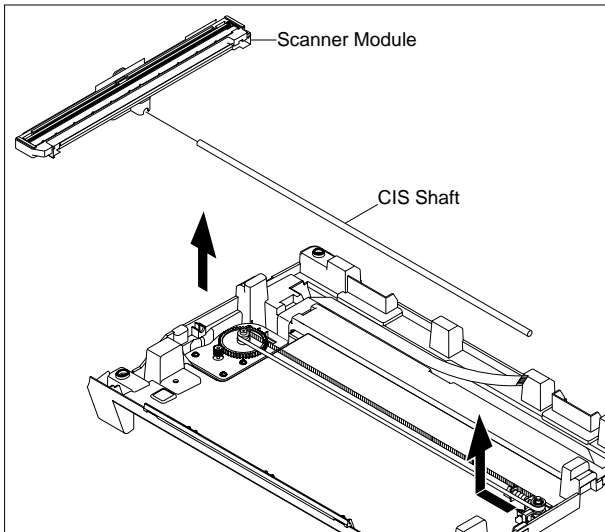

5. Push the Belt Holder and take out the Belt, as shown below.

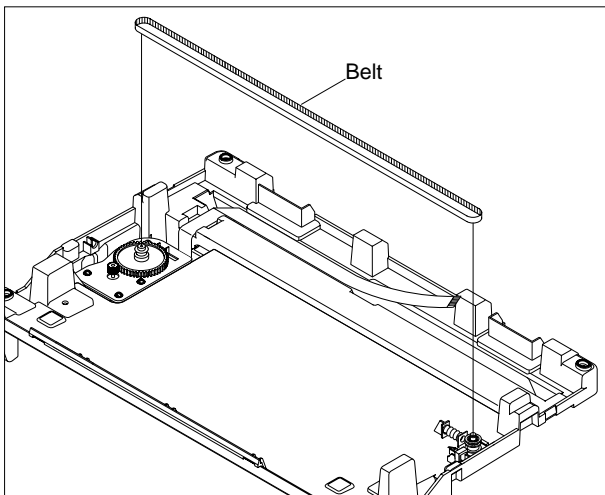

6. Remove the Pulley Idle, as shown below.

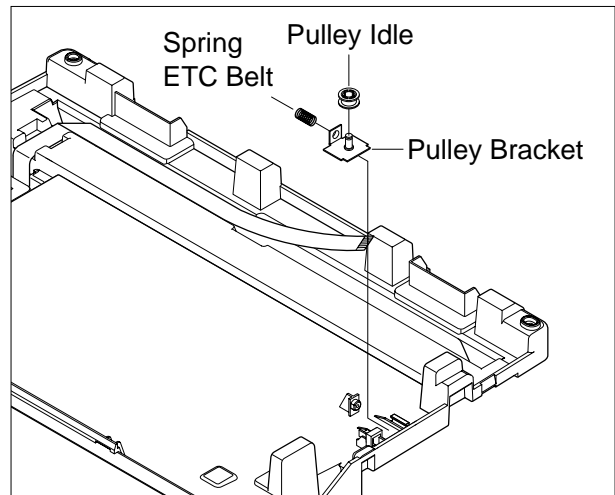

7. Remove the 2 screws and take out the Scan Motor Ass'y.

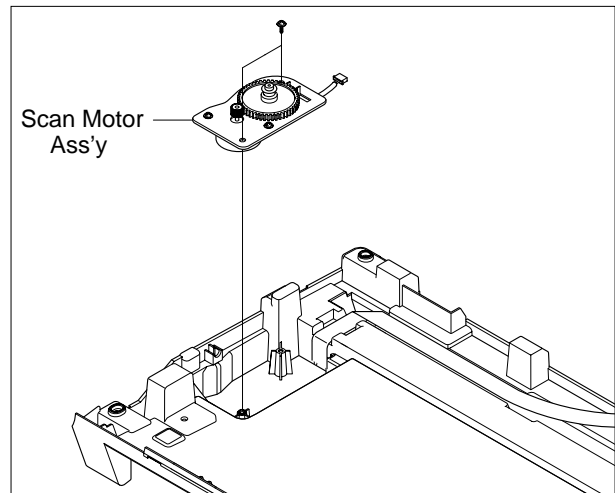

5.5 Middle Cover

1. Disconnect the OPE harness from the Main PBA and remove the 4 screws securing the Middle Cover. Remove it, as shown below.

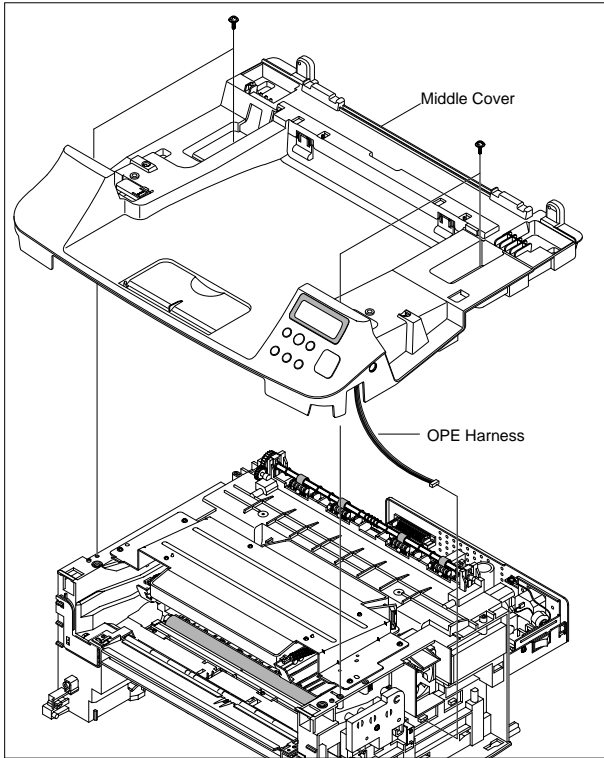

2. Remove the 4 screws securing the OPE Unit from the Middle Cover.

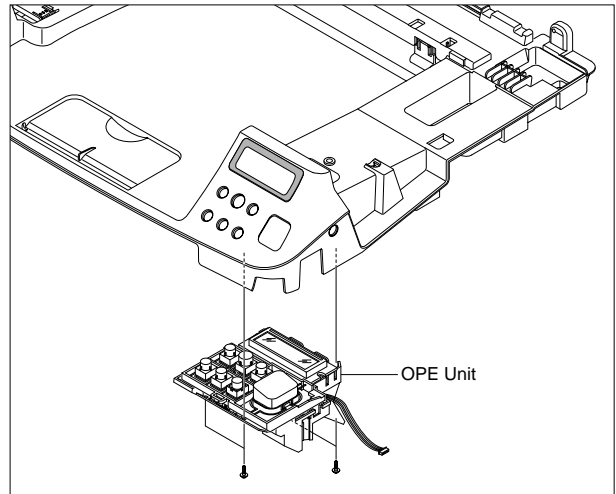

5.6 Fuser(Heat Lamp Type)

1. Before you remove the Fuser, you should remove:
-Rear Cover (see page 5-2)
2. Unplug two connectors from the boards and then remove 4 screws. Remove the Fuser Ass'y taking care not to damage the Exit Sensor.

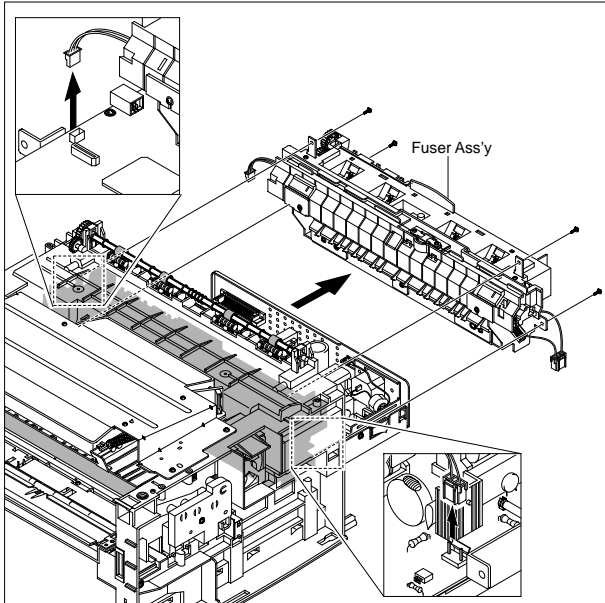

3. Remove 2 screws and take the Thermostat out of the Fuser.

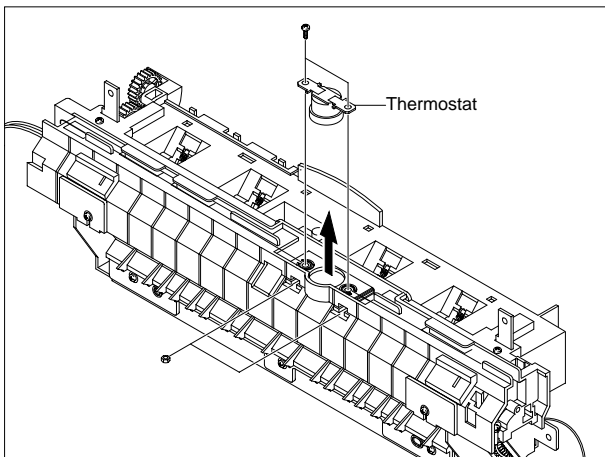

4. Remove 2 screws and take the Halogen Lamp out of the Heat Roller.

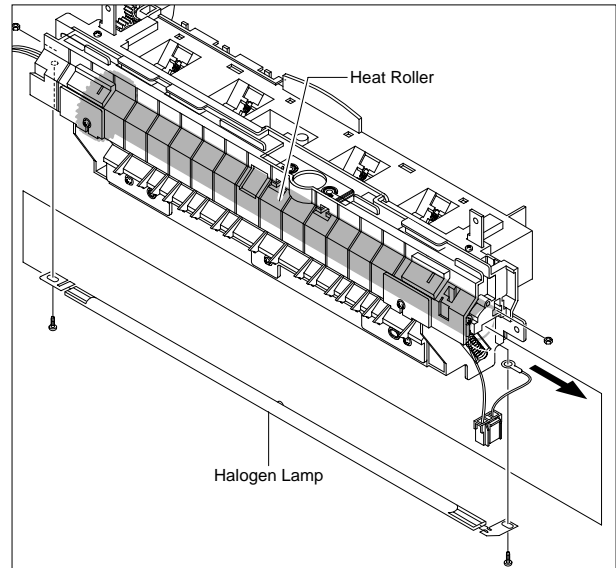

5. Remove 1 screw and take the Idle Gear out.

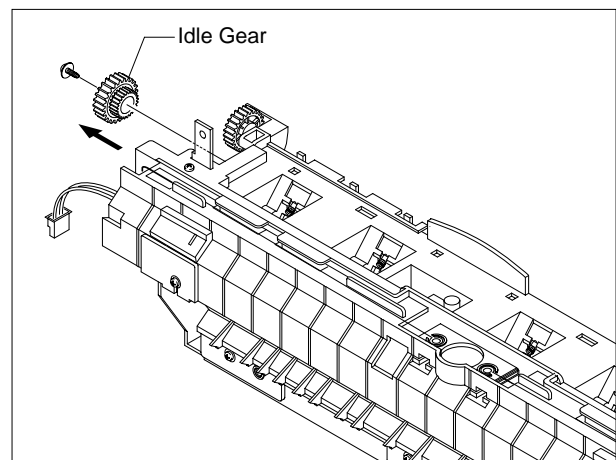

6. Remove 4 screws and divide the Fuser into two parts.

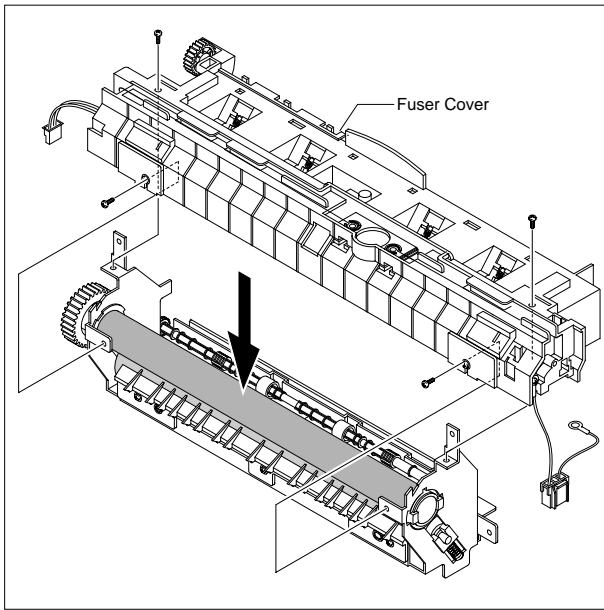

8. Remove the Thermister from the Fuser Cover.

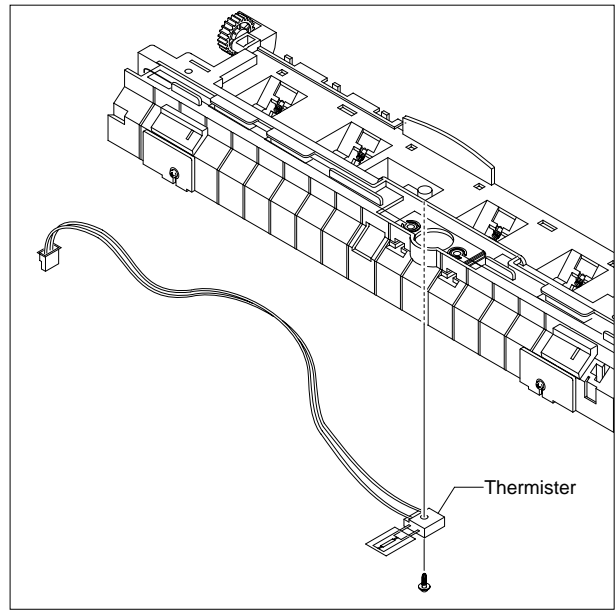

7. Unwrap the Thermister Harness, as shown below.

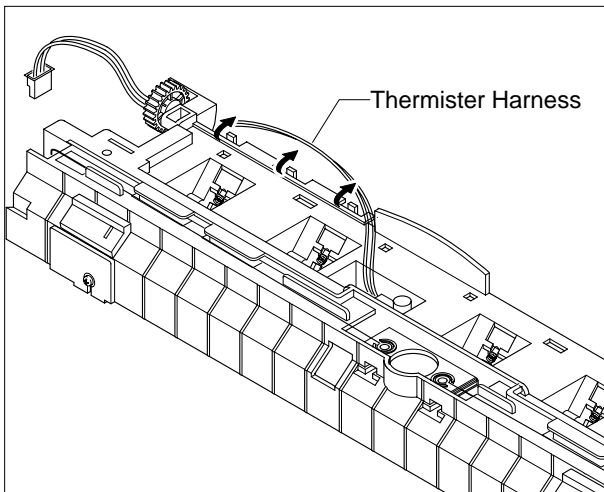

5.7 Exit Roller

1. Before you remove the Exit Roller you should remove:

- Rear Cover (see page 5-2)
- Side Covers (see page 5-3)
- Scanner Ass'y (see page 5-4)
- Middle Cover (see page 5-6)

2. Remove the white Exit Gear, and release a bearing clip at one end then remove the shaft and rollers as shown below.

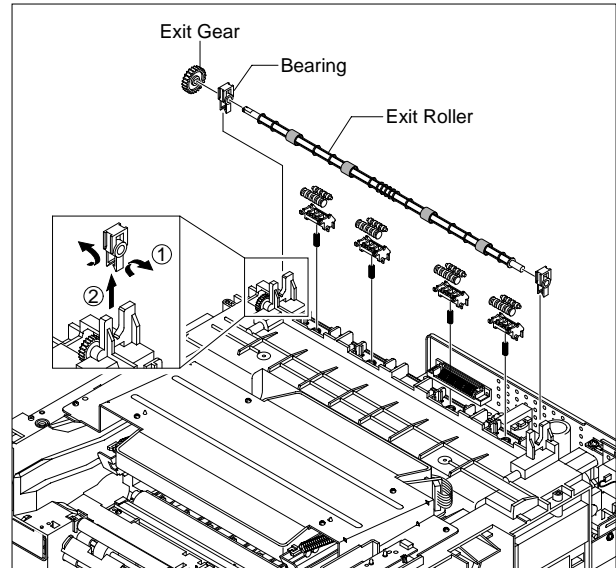

5.8 LSU

1. Before you remove the LSU you should remove:

- Rear Cover (see page 5-2)
- Side Covers (see page 5-3)
- Scanner Ass'y (see page 5-4)
- Middle Cover (see page 5-6)

2. Unplug 2 connector from the LSU.

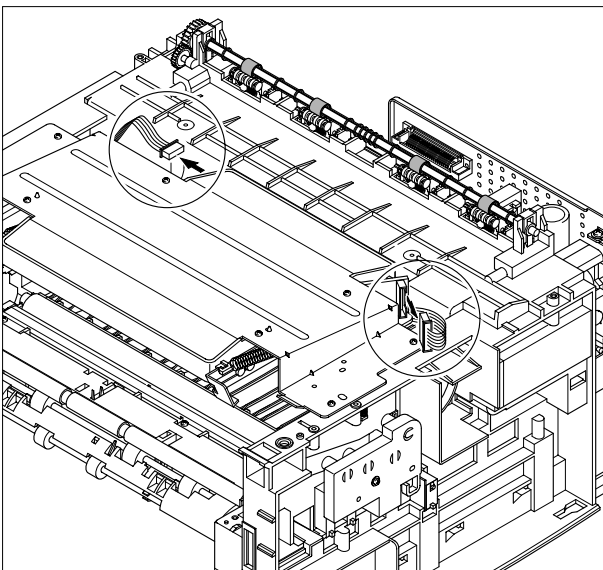

3. Unplug 4 screws and take the LSU out.

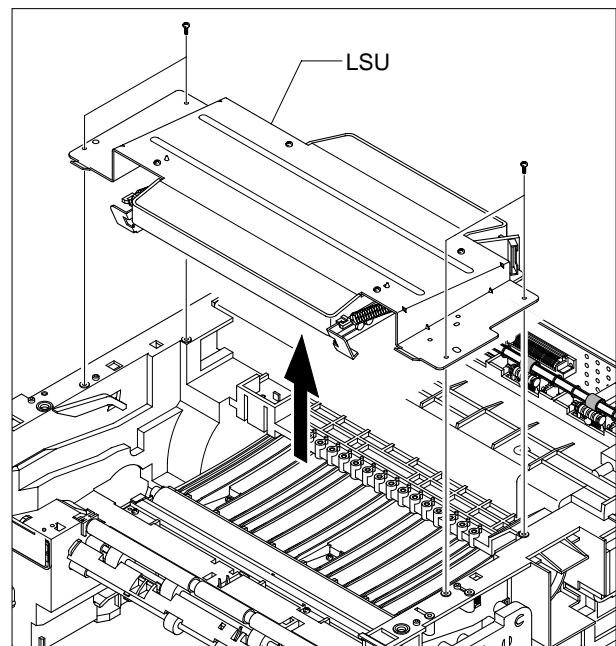

5.9 Fan

- Before you remove the Fan you should remove:
 - Rear Cover (see page 5-2)
 - Right Side Cover (see page 5-3)

- Unplug the connector from the SMPS and remove 1 screw. Then take out the Fan.

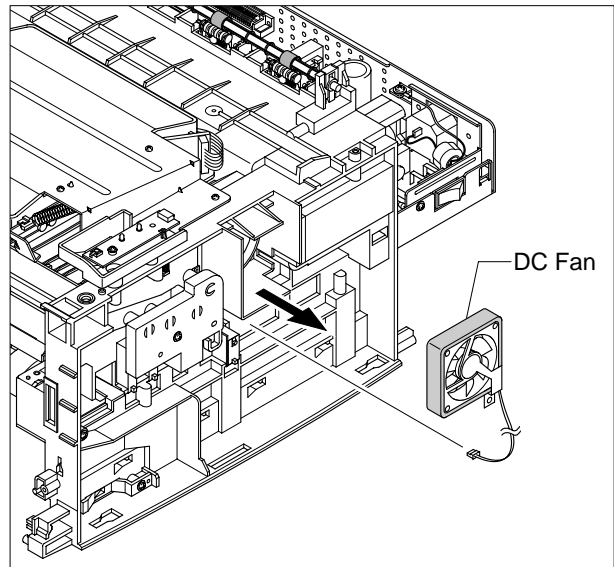

5.10 Drive Ass'y

- Before you remove the Drive Ass'y, you should remove:
 - Rear Cover (see page 5-2)
 - Left Side Cover (see page 5-3)

- Remove the 6 screws from the Drive Ass'y.

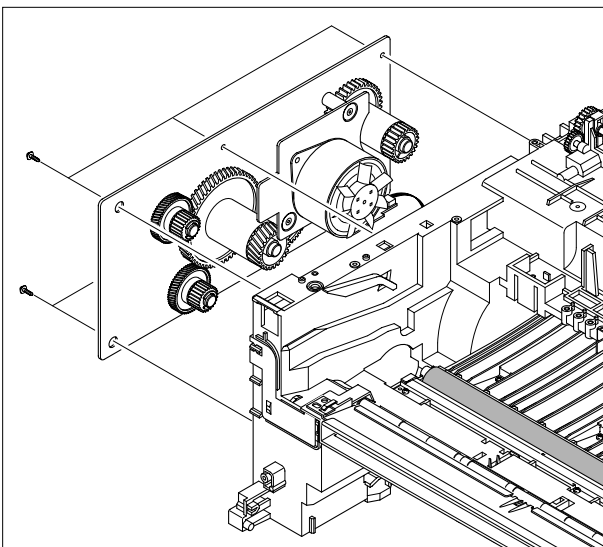

- Unplug 1 connector from the Drive Ass'y.

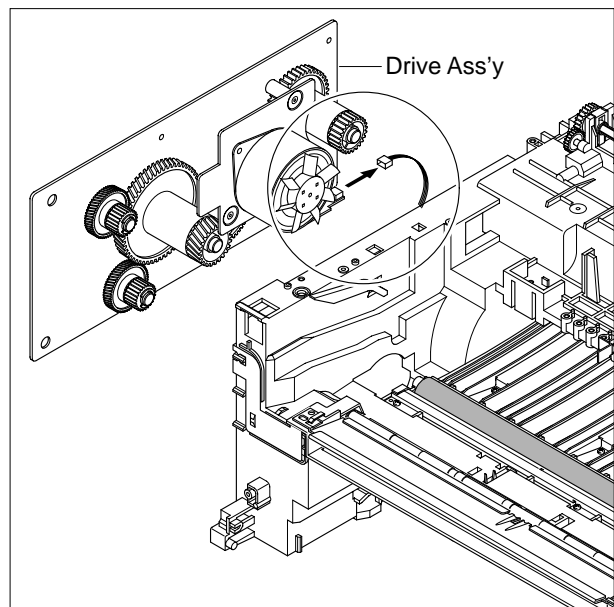

Note when re-fitting the motor Drive Ass'y tighten the screws in the order that they are numbered on the Motor Drive Ass'y base plate.

5.11 Engine Shield Ass'y

1. Before you remove the Fuser, you should remove:

- Rear Cover (see page 5-2)
- Side Covers (see page 5-3)
- Fuser Connector (see page 5-7)

2. Remove the 14 screws securing the Engine Shield Ass'y and unplug the all connectors. Then remove the Engine Shield Ass'y.

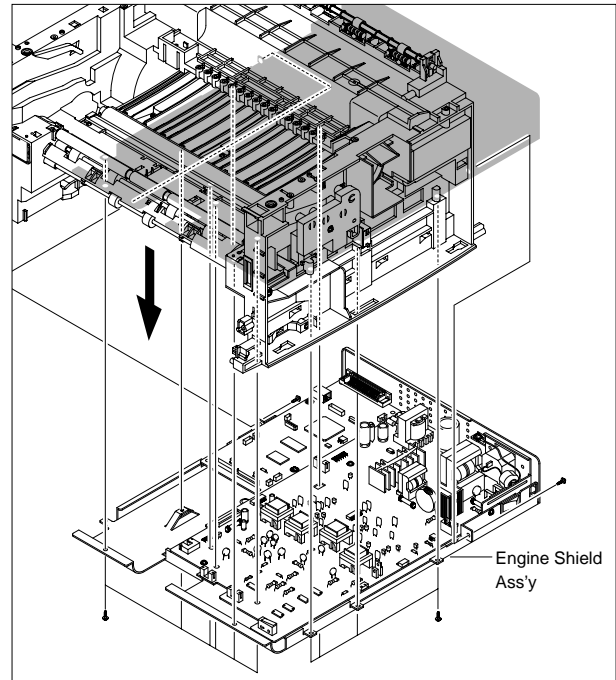

5.12 Main PBA

1. Before you remove the Main PBA, you should remove:

- Rear Cover (see page 5-2)
- Side Covers (see page 5-3)
- Fuser Connector (see page 5-7)
- Engine Shield Ass'y (see page 5-11)

2. Unplug 1 connector and remove 5 screws from the Main PBA. Then lift the Main PBA out as shown below.

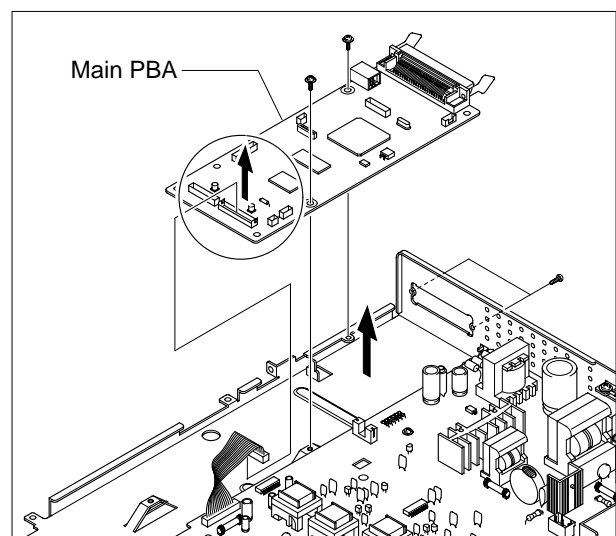

5.13 SMPS

1. Before you remove the SMPS, you should remove:

- Rear Cover (see page 5-2)
- Side Covers (see page 5-3)
- Fuser Connector (see page 5-7)
- Engine Shield Ass'y (see page 5-11)

2. Unplug 1 connector and remove 3 screws then take the Inlet Bracket out.

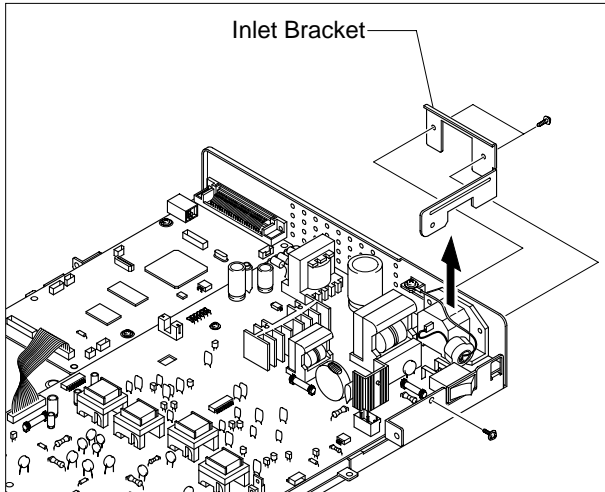

3. Remove 1 screw and unplug 1 connector from the Main PBA.

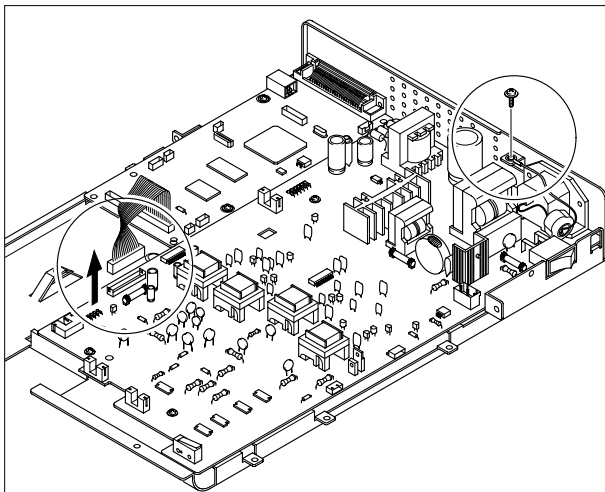

4. Remove 3 screws and take the SMPS out.

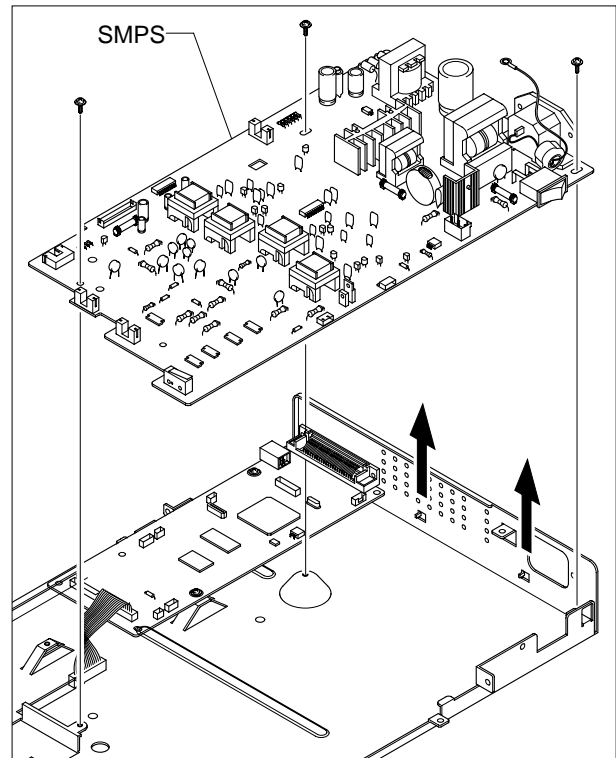

5.14 Transfer Roller

- Before you remove the Transfer Roller you should remove:
 - Rear Cover (see page 5-2)
 - Side Covers (see page 5-3)
 - Scanner Ass'y (see page 5-4)
 - Middle Cover (see page 5-6)
 - LSU(see page 5-9)
- Remove 3 screws and take the Transfer Earth out.

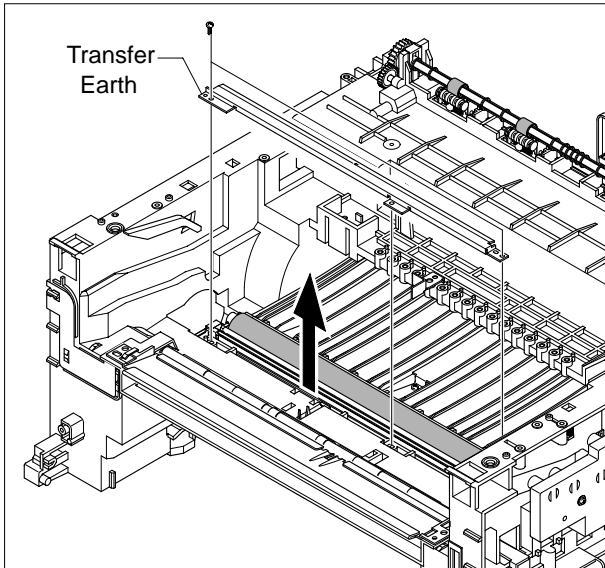

- Unplug the PTL Holder Connector then remove the PTL Holder and PTL Lens as shown below. Take care to note the orientation of the PTL lens and ensure it is refitted correctly

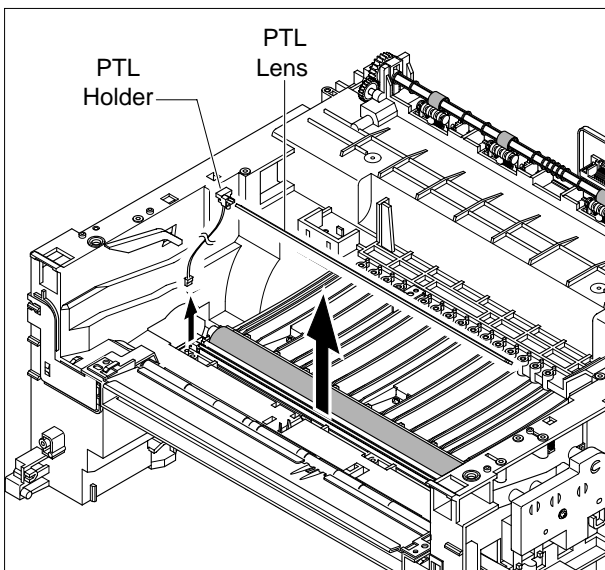

- Unlatch the Bush and remove it. Then lift the Transfer Roller out, as shown below.

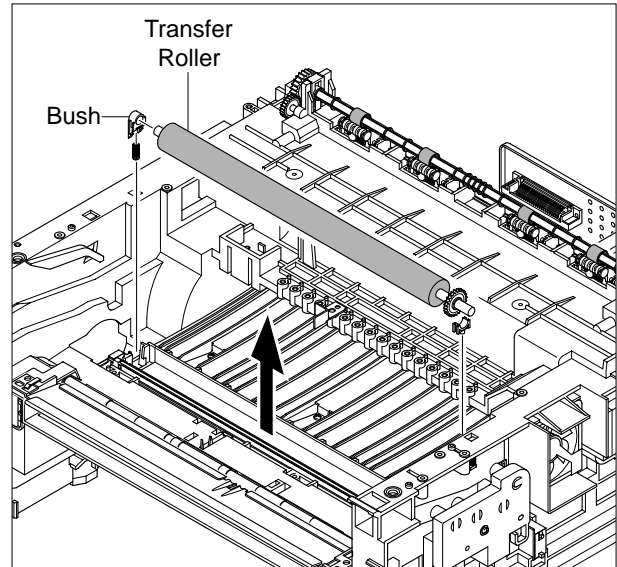

5.15 Feed Roller

1. Before you remove the Feed Roller you should remove:

- Rear Cover (see page 5-2)
- Side Covers (see page 5-3)
- Scanner Ass'y (see page 5-4)
- Middle Cover (see page 5-6)
- LSU (see page 5-9)
- Drive Ass'y (see page 5-10)

2. Remove 2 screws from the Guide Paper and take it out.

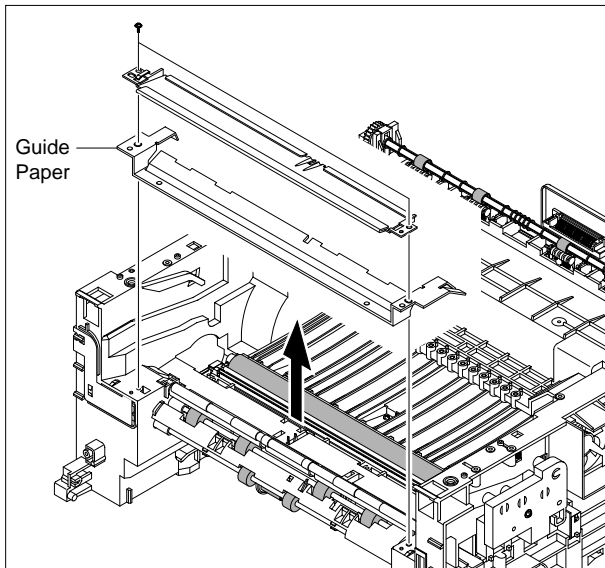

3. Pull up the Feed Idle Bush and Feed Idle Shaft, as shown below.

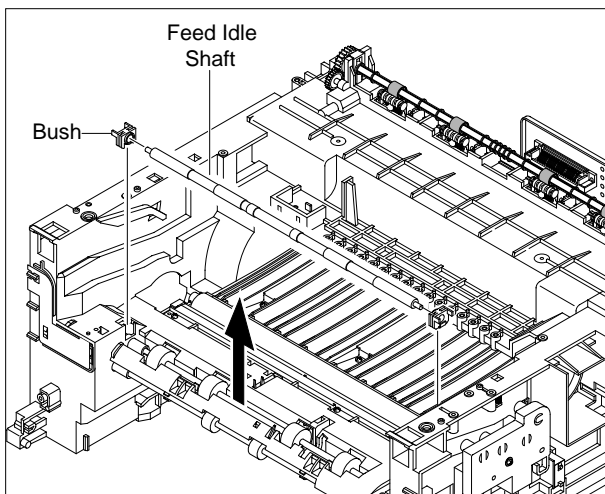

4. Remove 3 screws from the Feed Bracket and take it out.

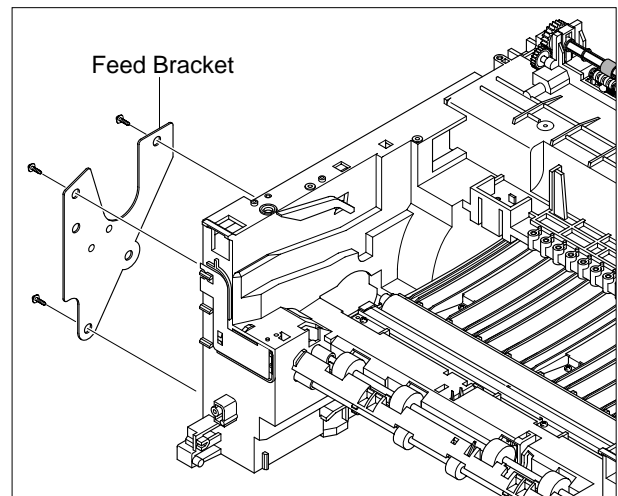

5. Remove the Idle Gear and Feed Gear2.

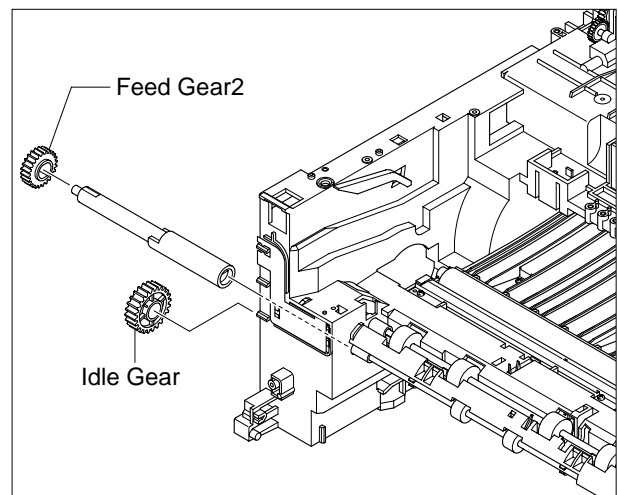

6. Remove the Feed Gear 1 Ass'y, as shown below.

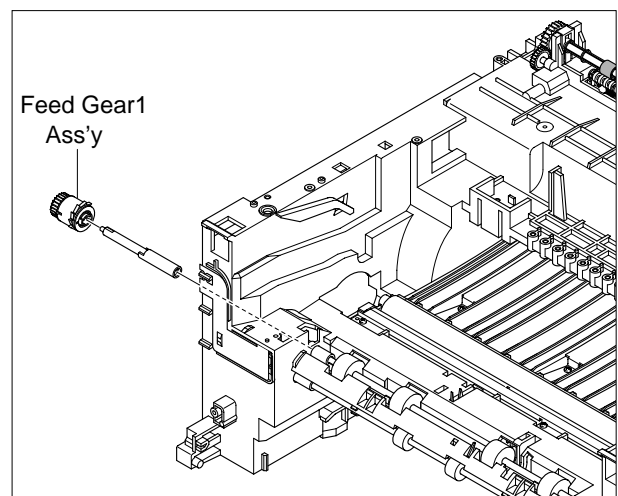

7. Remove the Feed Roller and Feed Roller1, as shown below.

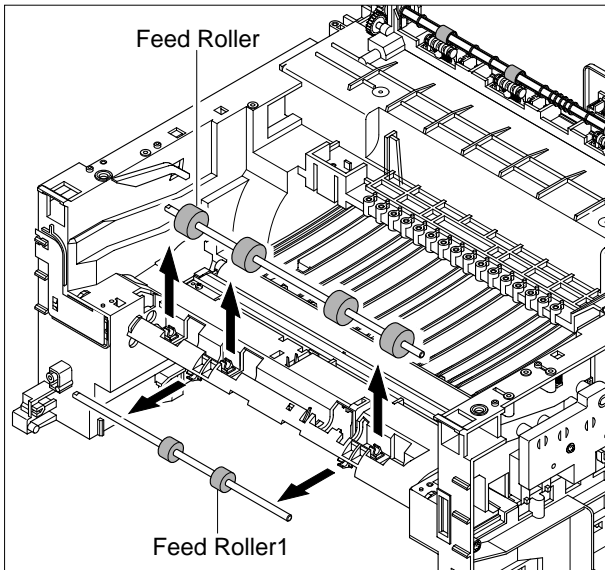

5.16 Pick Up Roller & Solenoid

- Before you remove the Pick Up Roller and Solenoid you should remove:
 - Rear Cover (see page 5-2)
 - Side Covers (see page 5-3)
 - Scanner Ass'y (see page 5-4)
 - Middle Cover (see page 5-6)
 - LSU (see page 5-9)
 - Drive Ass'y (see page 5-10)
 - Feed Bracket and Gears (See page 5-14 steps 4 - 6)

- Remove the Pick up Gear Ass'y, as shown below.

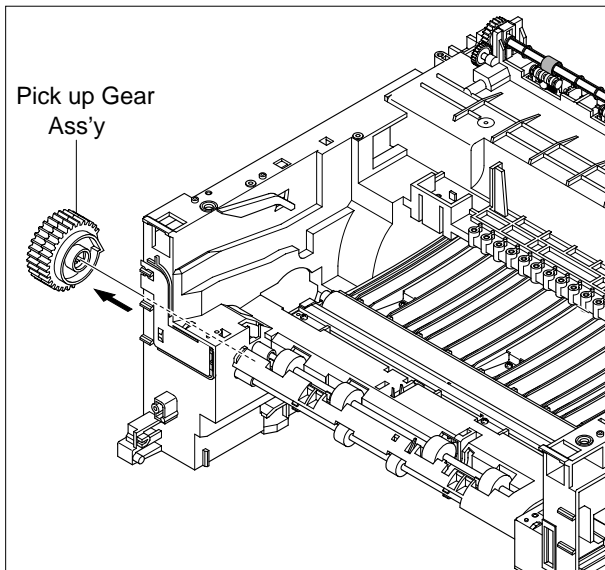

- Remove the Pick up Ass'y, as shown below.

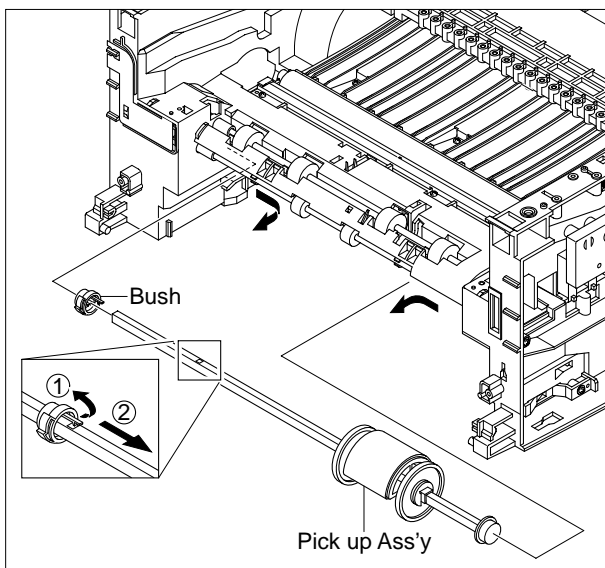

- Remove 2 screws then remove the Regi Solenoid and Pick Up Solenoid.

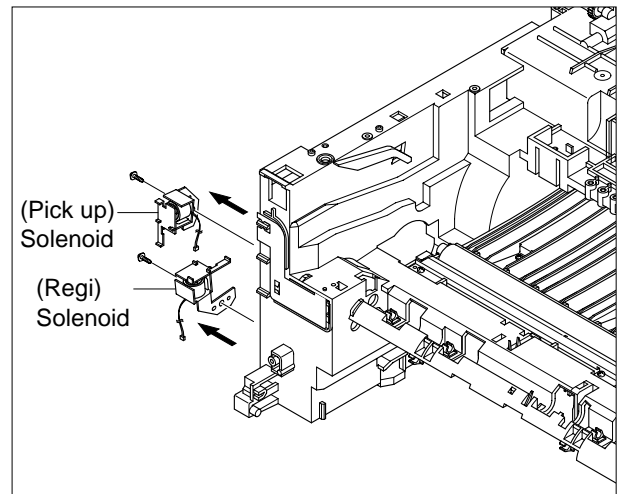

MEMO



6. Alignment and Adjustments

This chapter describes some of the main service procedures including:
Using the EDC mode; Clearing paper jam and test patterns.
Much of this chapter is also included in the user's guide.

6.1 Engine Test Mode

The Engine Tests Mode supplies useful functions to check the condition of the engine. It tests the condition of each device and displays the result of the test on the LCD. It is classified into 5 functions (0~4), and are shown below.

6.1.1 To enter the Engine Test Mode

To enter the Engine Test mode

Press  →  →  →  →  →  in sequence, and the LCD briefly displays

'**Engine Test [Diagnostic]**', the machine has entered Engine Test Mode.

- To enter a lower menu (Sub menu) Press the Start/Enter key.
- To exit into an upper menu Press the Menu/Exit key.
- To return to the user menu Press the Menu/Exit key.

6.1.2 Diagnostic

Main Menu	Engine test	Remark
ENGINE TEST MTR FAN SOL ETC	Motor Test	1 : On, 2 : Off
	PickUp Test	1 : On, 2 : Off
	Fan Test	1 : On, 2 : Off
	Manual Clt Test	1 : On, 2 : Off
	PTL Test	1 : On, 2 : Off
ENGINE TEST LSU TEST	LSU Motor Test	1 : On, 2 : Off
	LSU Hsync Test	1 : On, 2 : Off
	LD Test	1 : On, 2 : Off
ENGINE TEST SENSOR TEST	Feed Sen Test	Check : Check Start Next : Next Sensor Check
	Exit Sen Test	Check : Check Start Next : Next Sensor Check
	Cover Sen Test	Check : Check Start Next : Next Sensor Check
	Empty Sen Test	Check : Check Start Next : Next Sensor Check
	Manual Sen Text	Check : Check Start Next : Next Sensor Check
ENGINE TEST HEAT TEST	Therm ADC 220~85	1 : On, 2 : Off (maintain the fusing temp. 65C~230C)
ENGINE TEST HVPS TEST	MHV Test	1 : On, 2 : Off (-1550V ± 50V)
	Dev Bias Test	1 : On, 2 : Off (-430V ± 20V)
	THV EN/NEG Test	1 : On, 2 : Off (-1000V +300V/-150V)
	THV ON (1300V)	1 : On, 2 : Off (+1300V ± 20V)
	THV ADC 1300V	1 : On, 2 : Off
	THV ADC 600V~3550V	1 : On, 2 : Off (Compare each ADC Value)

6.2 Paper Path

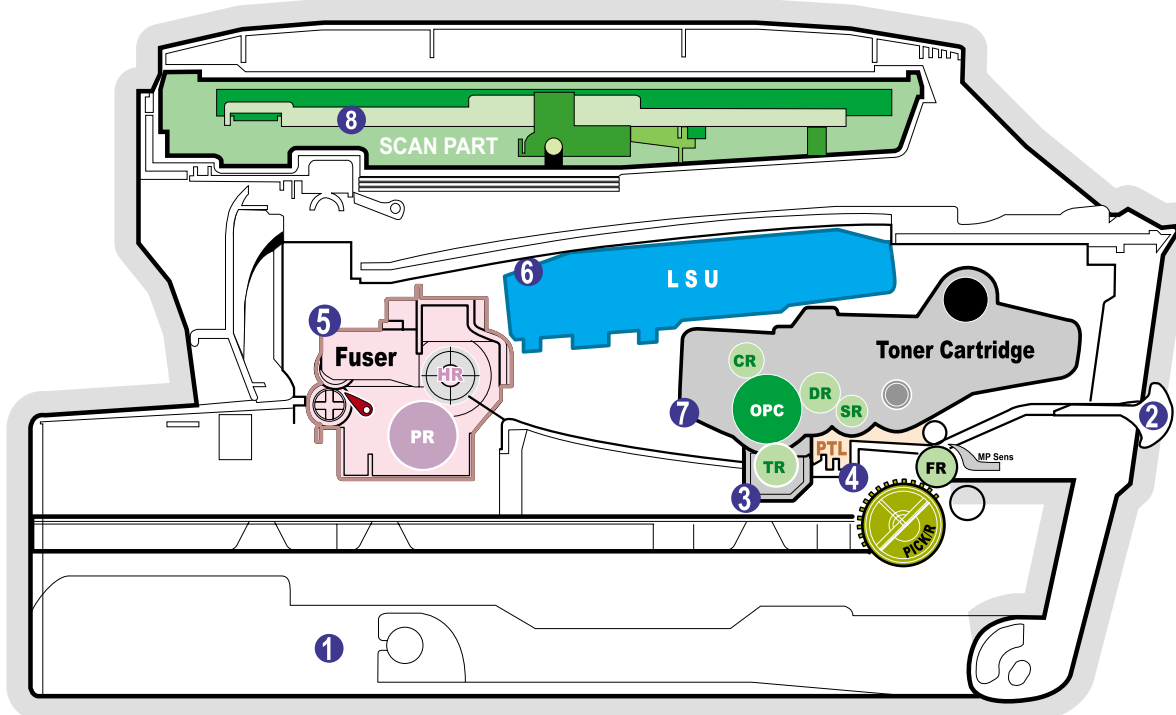

- | | |
|--------------------------|------------------------|
| ① Cassette | ⑤ Fuser |
| ② Manual Feeder | ⑥ LSU(Laser Scan Unit) |
| ③ Transfer Roller | ⑦ Toner Cartridge |
| ④ PTL(Pre-Transfer-Lamp) | ⑧ Scan Unit |

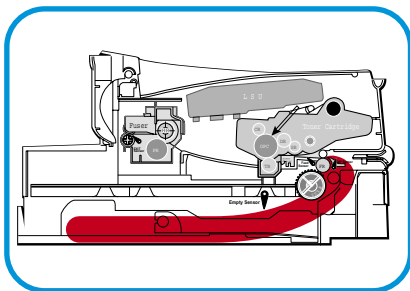

<Jam0>

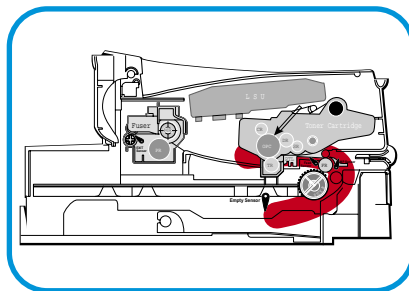

<Jam1>

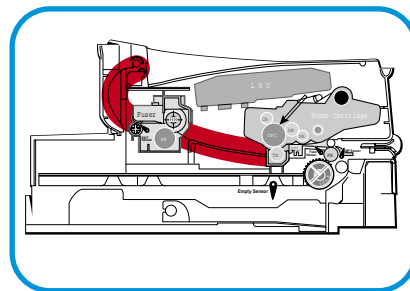

<Jam2>

- 1) After receiving a print command, the printer feeds paper from the main cassette or manual feeder as required.
- 2) The paper being fed passes the paper feed sensor. (Jam 0 occurs if the sensor is not operated within a certain time)
- 3) Having passed the paper feed sensor the paper moves to the paper exit sensor via printing process. (Jam 1 occurs if the sensor is not operated within a certain time)
- 4) The paper then passes through the paper exit sensor and out of the set. (Jam 2 occurs if the trailing edge of the paper does not pass the exit sensor within a certain time of the paper leading edge activating the exit sensor)

6.3 Clearing Paper Jams

When a paper jam occurs, "Paper Jam" appears on the display. Refer to the table below to locate and clear the paper jam.

Message	Location of Jam
PAPER JAM 0 OPEN/CLOSE DOOR	In the paper tray
PAPER JAM 1 OPEN/CLOSE DOOR	In the paper exit area
PAPER JAM 2 CHECK INSIDE	In the fuser area or around the toner cartridge
BYPASS JAM	In the manual feeder

To avoid tearing the paper, pull the jammed paper out gently and slowly. Follow the steps on the next pages to clear the jam.

6.3.1 In the Paper Tray

1 Open and close the front cover. The jammed paper is automatically ejected from the machine. If the paper is not ejected continue to step 2.

2 Pull the paper tray open.

3 Remove the jammed paper by gently pulling it straight out.

4 Insert the paper tray into the machine until it snaps into place.

5 Open and close the front cover to resume printing.

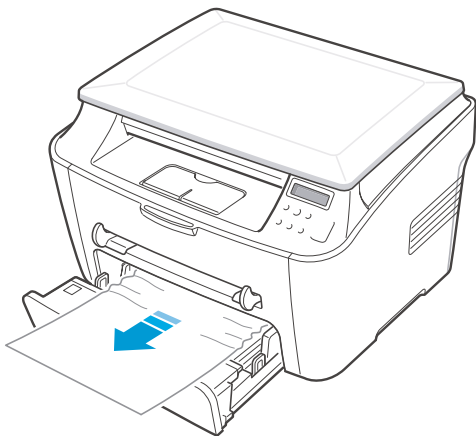

If there is any resistance and the paper does not move when you pull or if you cannot see the paper in this area, skip to the fuser area around the toner cartridge. See page 6-5

6.3.2 In the Paper Exit Area

1 Open and close the front cover. The jammed paper is automatically ejected from the machine. If the paper is not ejected continue to step 2.

2 Gently pull the paper out of the front output tray.
Skip to step 9.
If you cannot see the jammed paper in the front output tray, continue to step 3.

3 Open the jam cover by lifting the front edge of the scanner unit. The support lever will automatically pop up.

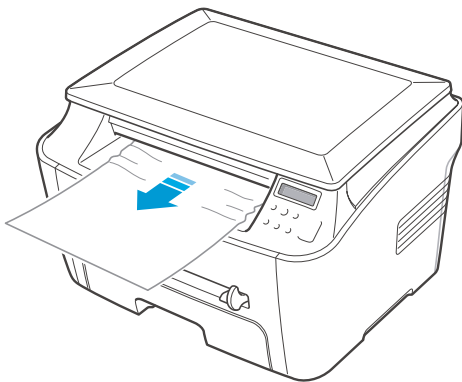

4 Pull the paper out gently.

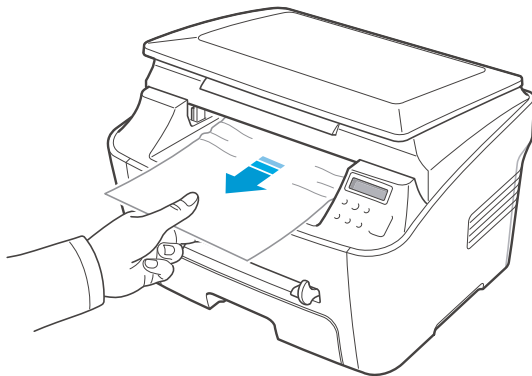

5 Close the jam cover by pushing the support tab to the left and hold it down whilst lowering the cover carefully until the cover fully down, this will hold down the tab.

If there is any resistance and the paper does not move when you pull or if you cannot see the paper in the jam cover, continue to step 6.

6 Open the rear cover.

7 Remove the jammed paper by gently pulling it straight out.

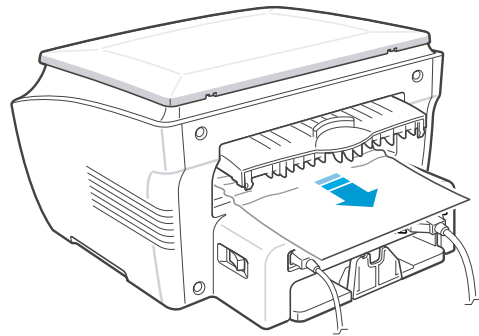

8 Close the rear cover.

9 Open and close the front cover to resume printing.

6.3.3 In the Fuser Area or Around the Toner Cartridge

NOTE: The fuser area is hot. Take care when removing paper from the machine.

1 Open the front cover and lightly push down on the cartridge then pull to take it out.

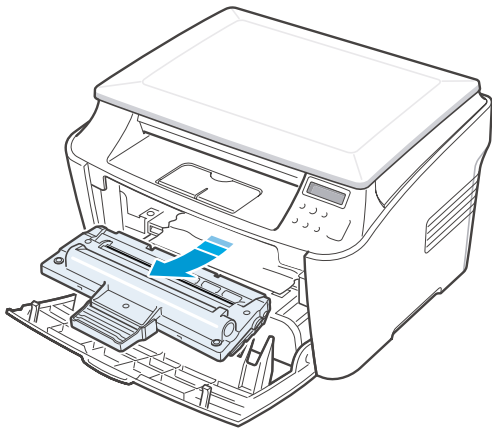

2 Remove the jammed paper by gently pulling it straight out.

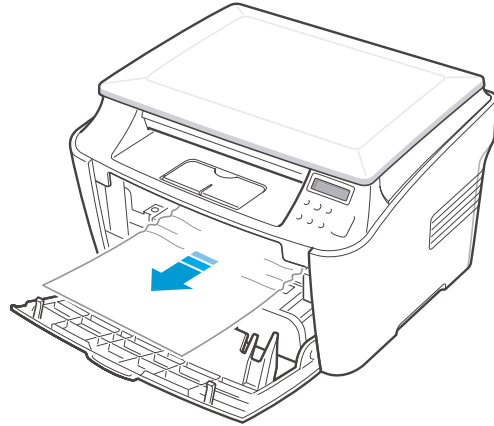

3 Replace the toner cartridge and close the front cover.
Printing automatically resumes.

6.3.4 In the Manual Feeder

“Bypass Jam” appears on the display when you try to print using the manual feeder and the machine does not detect paper, due to no paper or improper paper loading.

The error message may also occur when the paper is not properly fed into the machine through the manual feeder. In that case, pull the paper out of the machine.

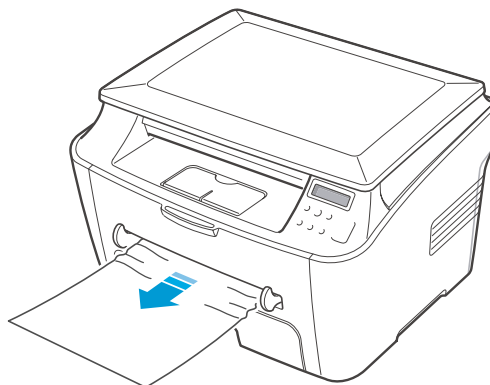

6.4 Printing the System Data List

Your machine can print the system data report which shows the status of the user-selectable options. You may print this list to confirm your changes after changing any settings.

To print the system data list:

- 1 Press **Menu/Exit** until "Report" appears on the top line of the display.
"System Data" appears on the bottom line.
- 2 Press **Start/Enter**.
The system data list prints out.

6.5 Clearing the Memory

You can selectively clear information stored in your machine's memory.

- 1 Press **Menu/Exit** on the control panel until "Maintenance" appears on the top line of the display.
- 2 Press the scroll button (< or >) until you see "Clear Settings" on the bottom line and press **Start/Enter**.
The first available menu item, "Paper Setting" displays on the bottom line.
- 3 Press the scroll button (< or >) until you see the item you want to clear.
 - Paper Setting: Restores all of the Paper Setting options to the factory default.
 - Copy Setup: Restores all of the Copy Setup options to the factory default.
 - All Settings: Resets all of your settings to the factory default.
 - Machine Setup: Resets all of the system settings, such as the display language and save modes, to the factory default.
- 4 Press **Start/Enter**. The selected memory is cleared and the display asks you to continue clearing the next item.
- 5 To clear another item, press **Start/Enter** and repeat steps 3 and 4. Or, to return to Standby mode, press **Stop/Clear**.

6.6 Clearing the Drum

If there are streaks or spots on your print, the OPC drum of the cartridge may require cleaning.

- 1 Before carrying out the cleaning procedure, make sure that paper is loaded in the machine.
- 2 Press **Menu/Exit** on the control panel until "Maintenance" appears on the top line of the display.
The first available menu item, "Clean Drum", displays on the bottom line.
- 3 Press **Start/Enter**.
- 4 When the display asks you to confirm your selection, press **Start/Enter**.
The machine prints a cleaning page. Toner particles on the drum surface are affixed to the paper.
- 5 If the problem remains, repeat steps 1 through 4.

6.7 Consumables and Replacement Parts

The cycle period outlined below is a general guideline for maintenance.
 The example list is for an average usage of 50 transmitted and received documents per day.
 Environmental conditions and actual use will vary these factors.
 The cycle period given below is for reference only.

COMPONENT	REPLACEMENT CYCLE	
Pick-up Roller	60,000 Pages	
Paper Feeding Roller(Friction Pad)	60,000 Pages	
Transfer Roller	60,000 Pages	
Fuser	60,000 Pages	
Toner Cartridge	Original 1,000 Pages	Replacement 3,000 Pages

6.8 The LCD Status Display by Each Error

LCD	Meaning	Solutions
Door Open	The front or rear cover is not securely latched.	Close the cover until it locks into place.
[JAM 1] or [No Cartridge]	The toner cartridge is not installed.	Install the toner cartridge.
Low Heat Error Open Heat Error [Over Heat]	There is a problem in the fuser unit.	Unplug the power cord and plug it back in. (Tech Mode Reference)
[LSU Error]	A problem has occurred in the LSU (Laser Scanning Unit).	Unplug the power cord and plug it back in. (Tech Mode Reference)
No Paper [Add Paper]	The paper tray has run out of paper.	Load paper in the paper tray.
Paper Jam 0 Open/Close Door	Paper has jammed in the feeding area of the paper tray.	Clear the jam.
Paper Jam 1 Open/Close Door	<ul style="list-style-type: none"> • Paper has jammed in the fuser area. • A paper jam has occurred in the manual feeder or the machine detects non-feeding from the manual feeder. 	<ul style="list-style-type: none"> • Clear the jam. • Clear the jam.
Paper Jam 2 Check Inside	Paper has jammed in the paper exit area.	Clear the jam.

6.9 Periodic Defective Image

If a mark or other printing defect occurs at regular intervals down the page it may be caused by a damaged or contaminated roller. Measure the repetition interval and refer to the table below to identify the roller concerned.

No	Roller	Defective image	Typical defect
1	OPC Drum	75.5mm	white spot on black image or black spot
2	Charge Roller	37.7mm	black spot
3	Supply Roller	47.8mm	light or dark horizontal image band
4	Developing Roller	35.2mm	horizontal image band
5	Transfer Roller	45.3mm	image ghost
6	Heat Roller	57.1mm	Black spot and image ghost
7	Pressure Roller	59.7mm	black spot on the backside

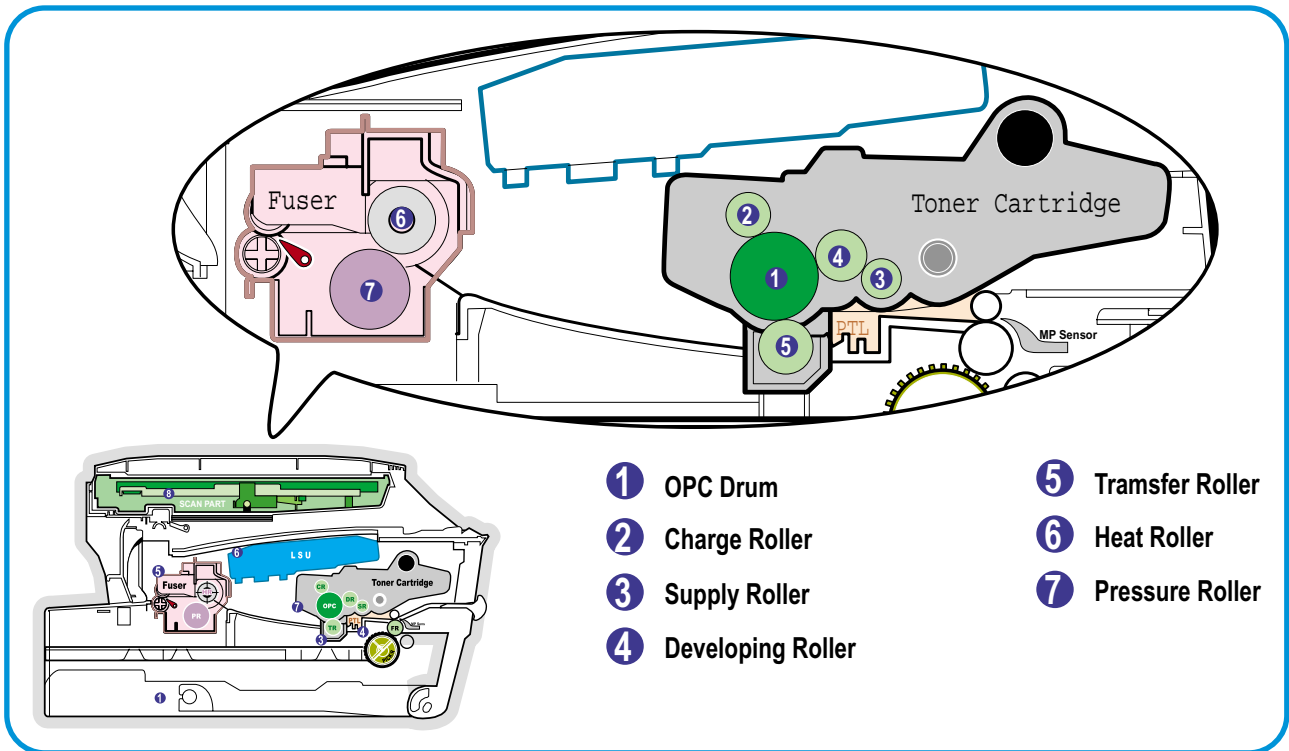

<Rollers Layout>

7. Troubleshooting

7.1 Printing Problems – Causes and Solutions

7.1.1 Vertical Black Lines and Bands

- **Description** 1. Straight thin black vertical lines occur in the printing.
2. Dark black vertical bands occur in the printing.

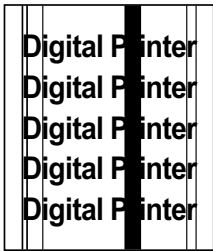

Check and Cause	Solution
1. Damaged developer roller, deformed Doctor-blade or cleaning-blade in the Toner cartridge.	1. Replace the toner cartridge and test again.
2. Scratched surface of the charge roller in the toner cartridge.	2. Replace the toner cartridge and test again.
3. 3. Depression or deformation of the surface of the transfer roller.	3. Replace the transfer roller and test again.

7.1.2 Vertical White Line

- **Description** White vertical voids in the image.

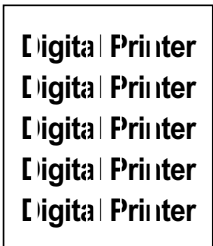

Check and Cause	Solution
1. 1. Contamination of the window or internal lenses of LSU mirror.	1. Clean the LSU window with recommended cleaner (IPA) Clean the window with a clean cotton swab. If dirt is inside the LSU – replace LSU.
2. Foreign object inside the toner cartridge or low toner.	2. Replace the toner cartridge.
3. Foreign object, contamination or burr on the edge of the toner cartridge window.	3. Clean the exposure window.
4. If the fuser is defective, voids occur periodically at the top of a black image.	4. Open the front cover and check the ribs that correspond to the position of the voids. Remove if found.
5. Contamination of the OPC drum.	5. If the problems are not solved, replace the toner cartridge.
6. Depression or deformation of the surface of the transfer roller	6. Replace the transfer roller.

7.1.3 Horizontal Black Bands

- **Description** 1. Dark or blurry horizontal stripes occur in the printing periodically. (These may occur at regular intervals down the page.)



Check and Cause	Solution
1. Bad contacts on the toner cartridge high voltage terminals. 2. The rollers in the toner cartridge may be contaminated. Charge roller = 37.7 mm Supply roller = 47.8 mm Develop roller = 35.2 mm Transfer roller = 45.3 mm	1. Clean all HV terminals on the cartridge and on the set frame. Ensure all toner or paper dust particles are removed. 2. Clean the right Gear that has relatively small tooth gap on the OPC. 3. If the problem persists replace the toner cartridge.

7.1.4 Black/White Spot

- **Description** 1. Dark or blurry black spots occur periodically in the printing.
2. White spots occur periodically in the printing.



Check and Cause	Solution
1. If dark or blurry black spots occur periodically, the rollers in the Developer may be contaminated with foreign matter or paper particles. (Charge roller : 37.7 mm interval OPC drum : 75.5 mm interval) 2. If faded areas or voids occur in a black image at intervals of 75.5 mm, or black spots occur elsewhere, the OPC drum surface is damaged. 3. If a black image is partially broken, the transfer voltage is abnormal or the transfer roller's life has expired.	1. Print several OPC cleaning Mode Prints and then run the Self-test 2 or 3 times. 2. 75.5 mm repetition: Examine the surface of the OPC drum and carefully clean with a soft, lint free cloth. If unsuccessful replace the cartridge. 37.7mm repetition: Replace the toner cartridge 3. The transfer roller guarantees 60,000 sheets printing. If the roller's life is expired, replace it. Note. Cleaning the inside of the set to remove excess toner particles or paper dust will reduce the occurrence of this problem..

7.1.5 Light Image

• **Description** The printed image is light, with no ghost.

Digital Printer
Digital Printer
Digital Printer
Digital Printer
Digital Printer

Check and Cause	Solution
1. Toner Save mode enabled	1. Ensure the Toner Save mode is off. Check set and driver settings.
2. Develop roller is contaminated or the toner cartridge is almost empty.	2. Replace the toner cartridge and try to print out again.
3. Ambient temperature is below than 10°C.	3. Wait 30 minutes after printer is powered on before you start printing.
4. Bad contact caused by dirty terminals on the toner cartridge or set.	4. Clean the cartridge and set contacts. Generally clean dirt from inside the set.
5. Abnormal output from the HVPS. (Run EDC mode – see sections 6.1.2 and 6.1.3)	5. Replace the HVPS if the problems are not solved by the above four instructions.

7.1.6 Dark Image or a Black

• **Description** The printed image is dark.

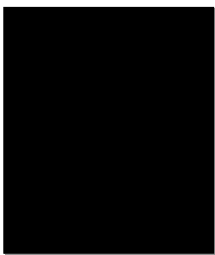

Check and Cause	Solution
1. No charge voltage in the engine board.	1. Check the state of the connector which connects the engine board and HVPS.
2. Charge voltage fault due to bad contact between toner cartridge and set contacts.	2. Clean the high voltage charge terminals. Note if 1 and 2 do not resolve the problem and the problem persists replace the HVPS.
3. VD0 signal of the Main PBA is Low state.	3. Replace the LSU Unit or Main PBA.

7.1.7 Uneven Density

• **Description** Print density is uneven between left and right.

Digital Printer
 Digital Printer
 Digital Printer
 Digital Printer
 Digital Printer

Check and Cause	Solution
1. The pressure force on the left and right springs of the transfer roller is not even, the springs are damaged, the transfer roller is improperly installed, or the transfer roller bushing or holders are damaged.	1. Replace both the left and right bush and spring assemblies.
2. The life of the Toner cartridge has expired.	2. Replace the toner cartridge and try to print out
3. The toner level is not even on the toner cartridge roller due to the damaged blade or low toner.	3. Gently shake the toner cartridge and try printing again. If the problem persists replace the toner cartridge.

7.1.8 Background

• **Description** Light dark background appears in whole area of the printing.

Digital Printer
 Digital Printer
 Digital Printer
 Digital Printer
 Digital Printer

Check and Cause	Solution
1. Printing large quantities of low coverage (2%) pages or the printer has not been used for a long time.	1. The toner cartridge is basically designed to print 3,000 sheets with 5% image. If it prints more than 3,600 sheets with 2% coverage, a background can occur.
2. Is a recycled toner cartridge be used?	2. The A/S is not guaranteed if using a recycled toner cartridge. Note try shaking the toner cartridge gently from side to side. If the problem persists replace the toner cartridge.
3. Has the life span of the toner cartridge ended?	3. Replace the toner cartridge when its life is expired.
4. Is the movement(Up and Down) of the transfer roller smooth?	4. Clean the transfer roller bushes.
5. Is the HVPS normal?	5. Clean the high voltage charge terminals. If this does not resolve the problem replace the HVPS.

7.1.9 Ghost (1)

• **Description** Ghost occurs at 75.5 mm intervals of the OPC drum in the whole printing.



Check and Cause	Solution
1. Bad contacts caused by contamination from toner particles between high voltage terminal in the main body and the electrode of the Toner cartridge.	1 and 2. Clean all HV contacts, If problem persists replace the HVPS. If problem still persists replace the Main PBA
2. Bad contacts caused by contamination from toner particles between high voltage terminal in the main body and the one in the HVPS board.	
3. The life of toner cartridge is expired.	3. Replace the toner cartridge and try to print out.
4. Transfer roller life (60,000 sheets) has expired.	4. Check the transfer roller lifetime and replace it.
5. Low ambient temperature (below 10°C).	5. Wait about 30 minutes after power on before using printer.
6. Damaged cleaning blade in the toner cartridge.	6. Replace the toner cartridge and try to print out again

7.1.10 Ghost (2)

• **Description** Ghost occurs at 75 mm intervals of the OPC drum in the whole printing. (When printing on card stock or transparencies using manual feeder)



Check and Cause	Solution
When printing on card stock, thicker than normal paper or transparencies, such as OHP, a higher transfer voltage is required.	Ensure that the correct paper type is selected in the printer driver or application software. Remember to set back to normal paper after use.

7.1.11 Ghost (3)

- **Description** Ghost occurs at 57 mm intervals.



Check and Cause	Solution
Fuser contamination.	1. Disassemble the fuser and remove any contamination on the rollers. Clean any contamination from between the Thermistor and the Heat roller. (Caution: Take care not to deform the rollers.)

7.3.12 Ghost (4)

- **Description** A White ghost occurs in a black image printing at 35.5 mm intervals.



Check and Cause	Solution
1. The life of the developer may be expired.	1. Problem in the toner cartridge, replace the toner cartridge and try to print out again.
2. Abnormal output from the HVPS. (Run EDC mode – see sections 6.1.2)	2. Check the HVPS supply voltage. Clean all HV terminals on the cartridge and on the set. Replace the HVPS if the problem persists.

7.1.13 Stains on the Face of the Page

- **Description** The background on the face of the printed page is stained.



Check and Cause	Solution
1. Toner leakage due to improperly sealed toner cartridge.	1. Replace the toner cartridge.
2. If the transfer roller is contaminated, stains on the face of page will occur.	2. If the transfer roller is contaminated, run PC Cleaning Mode Print 2 or 3 times and then perform Self-Test 2 or 3 times to remove contamination.

7.1.14 Stains on Back of Page

Description The back of the page is stained at 46.5 or 58.7 mm intervals.

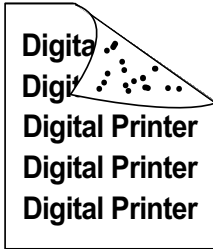

Check and Cause	Solution
1. 46.5mm : Transfer roller is contaminated.	1. Perform the OPC Cleaning Mode Print 2 or 3 times. Run Self-Test to remove the contamination from the transfer roller. Note. Replace the transfer roller if contaminated severely.
2. 58.7mm : Pressure roller is contaminated.	2. Disassemble the fuser and clean the H/R(Heat Roller) and P/R(Pressure roller). Check and clean the area between the H/R and the Thermistor. (Caution: Take care not to deform the rollers.)

7.1.15 Blank Page Print out (1)

Description Blank page is printed.

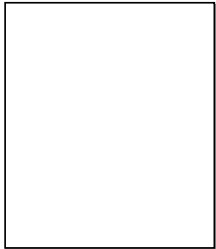

Check and Cause	Solution
Bad ground contacts in OPC and/or toner cartridge.	1. Check if the Ground-OPC or the OPC Ground Zener diode are defective or open circuit. (set inside left side). 2. Remove contamination of the terminals on the toner cartridge and the unit.

7.1.16 Blank Page Print out (2)

Description
 1. Blank page is printed.
 2. One or several blank pages are printed.
 3. When the printer turns on, several blank pages print.

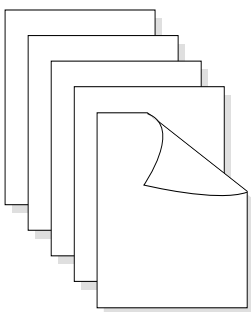

Check and Cause	Solution
1. Abnormal solenoid.	1. Perform the engine self test using TECH Mode to check if the Solenoid is normal. If the problem persists replace the main PBA

7.2 Copy Problems

7.2.1 White Copy

- **Description** Blank page is printed out when copying.

Check and Cause	Solution
<ol style="list-style-type: none"> 1. Check the Scanner Cover is properly closed. 2. Check shading profile. 3. Check white/black reference voltage on Main PBA. e.g <ul style="list-style-type: none"> • CIS_SI, CIS_CLK at CN7 • Or Check the FFC 	<ol style="list-style-type: none"> 1. Room light can pass through a thin original. 2. Redo shading profile in the tech mode. 3. Replace CN7 if it is defective. <ul style="list-style-type: none"> • CN7-Pin6(CIS-SI) • CN7-Pin7(CIS-CLK)

7.2.2 Black Copy

- **Description** Black page is printed out when Copying.

Check and Cause	Solution
<ol style="list-style-type: none"> 1. Check for CIS problem on the Main PBA. 2. Check shading profile. 	<ol style="list-style-type: none"> 1. Check the CIS harness is properly connected. 2. Redo shading profile in the tech mode.

7.2.3 Abnormal noise

• **Description** There is noise from the ADF when copying.

Check and Cause	Solution
<ol style="list-style-type: none"> 1. Check the Scanner Motor, gearbox and rollers. 2. Check the Motor Driver on Driver PBA. 	<ol style="list-style-type: none"> 1. Check for correct assembly of gears and motor. Ensure no parts are fouling and there are no foreign objects in the mechanism or scanner path. Replace any worn parts 2. Replace the main PBA.

7.2.4 Defective Image Quality

• **Description** The copied image is excessively light or dark

Check and Cause	Solution
<ol style="list-style-type: none"> 1. Check shading profile. 2. Check the gap between original and scanner glass. 3. Check printing quality. 	<ol style="list-style-type: none"> 1. Redo shading profile in the tech mode. 2. A gap of more than 0.5 mm can cause a blurred image. Ensure rollers and cover close correctly. Replace as necessary. 3. See "Print" troubleshooting.

7.3 Paper Feed problems – Causes and Solutions

7.3.1 Wrong Print Position

- **Description** Printing begins at wrong position on the paper.

Check and Cause	Solution
Wrong sensor timing caused by defective feed sensor actuator.	Replace the defective actuator

7.3.2 JAM 0

- **Description**
 1. Paper does not exit from the cassette.
 2. Jam-0 occurs when the paper feeds into the printer.

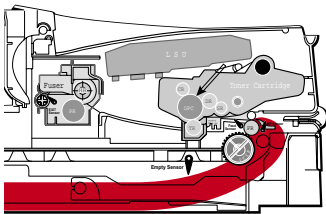

Check and Cause	Solution
1. Check the Solenoid by using Tech Mode.	1. Replace the solenoid.
2. Check cassette/MP knock-up plate and springs.	2. Repair / replace as required
3. Check paper separator pad	3 Clean with soft cloth dampened with IPA (Isopropyl Alcohol) or water. Replace if required.
4. Check the pick up roller for contamination and correct assembly.	4. Clean with soft cloth dampened with IPA (Isopropyl Alcohol) or water. Replace if required
5. If continuous clusters occur, check all rollers between pickup and registration sensor.	5. Ensure all rollers are clean and free to operate correctly.
6 If the paper feeds into the printer and Jam 0 occurs, perform Tech Mode to check feed sensor.	6. Check the SMPS PBA, Main PBA and all connections. Replace any faulty parts or the

7.3.3 JAM 1

Description

1. Paper is jammed in front of or inside the fuser.
2. Paper is stuck in the exit roller and in the fuser just after passing through the Actuator-Feed.

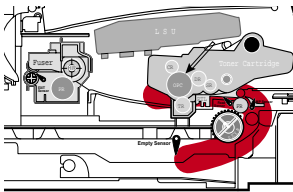

Check and Cause	Solution
<ol style="list-style-type: none"> 1. If the recording paper is jammed in front of or inside the fuser. 2. If the recording paper is stuck in the exit roller and the fuser just after passing through the Actuator-Feed, Feed Actuator may be defective. 	<ol style="list-style-type: none"> 1. Replace the Exit-Sensor, SMPS or main PBA. 2. Reassemble the Actuator-Feed and Spring-Actuator if the movement is bad. Replace if necessary.

7.3.4 JAM 2

Description

1. Recording paper is jammed in front of or inside the fuser.
2. Recording paper is stuck in the discharge roller and in the fuser just after passing through the Actuator-Feed.

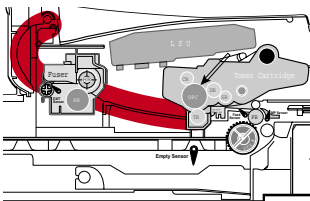

Check and Cause	Solution
<ol style="list-style-type: none"> 1. If the paper is completely fed out of the printer, but Jam 2 occurs: The Exit sensor may be defective. <ul style="list-style-type: none"> • After the paper is completely discharged the Exit sensor actuator should return to its original position to shut the photo-sensor. It may stick open or return only slowly due to contamination by paper debris or foreign objects. 2. If the paper is rolled in the Fuser Roller: <ul style="list-style-type: none"> • This occurs when a Guide claw is broken away, damaged or deformed. • It occurs when the Spring of a Guide claw is broken or damaged. • It occurs when the Heat-Roller or Pressure-Roller is seriously contaminated with toner. 	<ol style="list-style-type: none"> 1. Check if the exit sensor actuator is defective. <ul style="list-style-type: none"> • Check if the actuator exit is deformed (Check if the lever part is deformed). • Check whether burrs occur in the assembly part of the exit actuator and if the actuator operates smoothly. • Check if foreign objects or paper debris are preventing the correct operation of the actuator. 2. If the paper is stuck in the fuser : disassemble the fuser and remove the jammed paper, and clean the surface of the pressure roller with dry gauze. Check all ribs, claws and springs.

7.3.5 Multi-Feeding

- **Description** Multiple sheets of paper are fed at once.

Check and Cause	Solution
1. Check that the paper size guides are set correctly (cassette and MPF tray).	1. Adjust paper guides.
2. Solenoid malfunction (the solenoid does not work properly).	2. Replace the solenoids or PBA as appropriate.
3. Friction Pad is contaminated.	3. Clean the friction pad rubber with a soft cloth dampened with IPA (Isopropyl Alcohol) or water.
4. Paper has a rough surface texture.	4. Use paper with a smoother surface finish.

7.3.6 Paper rolled in the fuser

- **Description** Paper rolled around fuser rollers or 'Concertina' jam

Check and Cause	Solution
1. Contamination of the pressure roller or heat roller.	1. After disassembling the fuser, clean contamination from between the heat roller and the thermistor and also clean contamination from the pressure roller. Clean the surface of the rollers with IPA or water
2. Damaged or deformed ribs, claws or springs.	2. Check for damage or deformation of the print claws and the holder plate claws, and repair or replace as appropriate.

7.3.7 Paper rolled on the OPC Drum

- **Description** Paper is rolled up in the OPC.

Check and Cause	Solution
<ol style="list-style-type: none">1. Paper is too thin.2. The face of paper is curled.	<ol style="list-style-type: none">1. Use paper that conforms to the printer specification.2. Ensure paper is stored properly to prevent curl. <p>Note. To remove paper rolled in the OPC.</p> <ul style="list-style-type: none">• Remove the toner cartridge from the set, taking care not to touch the green surface. Use the gearwheel at the side to rotate the OPC drum and pull the paper from the cassette.• Clean fingerprints on the OPC gently with soft tissue, taking care not to scratch the surface.

7.4 Printer Faults – Causes and Solutions

7.4.1 Fuser Error

• **Description** A message "Open Heat Error/Over heat/Heating Error" is displayed in the LCD panel.

Check and Cause	Solution
1. Thermostat, fuser power cable or heat lamp is open circuit.	1. Replace the whole fuser assembly if the thermostat is open circuit.
2. Thermistor is open circuit.	2. Replace the whole fuser assembly if the thermistor sensor is faulty.
3. Heat lamp ON/OFF test	3. Replace the fuser.
4. Drive gear melted	

7.4.2 LSU Error

• **Description** A message "PMOTOR ERROR/HSYNC ERROR" is displayed in the LCD panel.

Check and Cause	Solution
1. LSU cable or connector faulty.	Use TECH mode to test the LSU - Replace the LSU - Replace a main board if the same error persists after replacing a LSU.
2. LSU motor is faulty.	
3. Check the HSYNC signal.	

7.4.3 Fuser gear melts due to overheating causing Paper Jam.

- **Description** Constant Jam where paper is entering Fuser unit.
Fuser rollers do not turn

Check and Cause	Solution
1. Check the Heat Lamp, thermostat and thermistor	1. Use EDC Mode to test the fuser. Replace Fuser unit Replace SMPS or Main PBA as appropriate.

7.4.4 Paper Empty

- **Description** Paper Empty is displayed in the LCD panel even when paper is loaded in the cassette.

Check and Cause	Solution
1. Deformed paper sensor actuator or faulty sensor. 2. SMPS PBA or Main PBA is defective 3. Faulty cables or connectors.	1. Replace the defective actuator or sensor. 2. Replace the SMPS PBA or MAIN PBA as appropriate.

7.4.5 Paper Empty without indication

- **Description** The paper empty message does not appear in the LCD when the paper cassette is empty.

Check and Cause	Solution
1. Deformed paper sensor actuator or faulty sensor. 2. SMPS PBA or Main PBA is defective .	1. Replace the defective actuator. 2. Replace the SMPS PBA or MAIN PBA as appropriate

7.4.6 Cover Open

- **Description** The Cover Open message appears on the LCD even when the print cover is closed.

Check and Cause	Solution
1. The 'Open Cover' microswitch may be stuck or faulty 2. The tab on the front cover may be damaged or broken 3. Check the connector and cables between Switch and main PBA.	1. Use TECH mode("cover sensor test") to check cover switch operation. Check and replace switch if necessary. 2. Replace the front cover. 3. Replace the Main Control board or Cover Open S/W as necessary.

7.4.7 No error message when the cover is open

• **Description** The Cover Open message does not appear on the LCD even when the print cover is open.

Check and Cause	Solution
<ol style="list-style-type: none"> 1. The 'Open Cover' microswitch may be stuck or faulty 2. Check the connector and cables between Switch and main PBA. 	<ol style="list-style-type: none"> 1. Use TECH mode("cover sensor test") to check cover switch operation. Check and replace switch if necessary. 2. Replace the Main Control board or Cover Open S/W as necessary.

7.4.8 Defective motor operation

• **Description** Main motor is faulty and paper does not feed into the printer, resulting in Jam 0'

Check and Cause	Solution
1. The main motor harness or Motor PCB may be faulty.	1. Check the motor harnesses and connectors, replace if defective.. If the problem persists replace the main PBA. Note Check motor operation using EDC Mode.

7.4.9 No Power

• **Description** When system power is turned on the LCD panel does not come on.

Check and Cause	Solution
1. Check if the power input and SMPS output are normal. 2. LCD panel does not come on but normal start up sounds are heard. 3. After replacing SMPS display does not come on and no start up sounds are heard.	1. Replace the power supply cord or SMPS. Check power fuse and SMPS fuses replace if necessary. 2. Replace the OP panel. 3. Replace the main PBA panel.

7.4.10 Printed Vertical Lines become curved

- **Description** When printing, vertical lines are not straight.

Check and Cause	Solution
1. Check stability of 24V supply to LSU.	1. 24V stable - Replace LSU. 24V unstable replace SMPS, if the problem persists replace the main PBA.

7.5 Toner Cartridge Service

Only toner cartridges supplied by Samsung should be used. Printing defects or set damage caused by the use of non-approved toner cartridges or un-licensed toner refills are not covered by the guarantee.

7.5.1 Precautions on Safe-keeping of Toner Cartridge

Excessive exposure to direct light for more than a few minutes may cause damage to the cartridge.

7.5.2 Service for the Life of Toner Cartridge

If the printed image is light due to the toner supply becoming low you can temporarily improve the print quality by redistributing the toner (Shake the toner cartridge), however you should replace the toner cartridge to solve the problem permanently.

7.5.2.1 Redistributing Toner

When the toner cartridge is near the end of its life, white streaks or light print occurs. You can temporarily reestablish the print quality by redistributing the remaining toner in the cartridge.

1. Open the Front Cover.

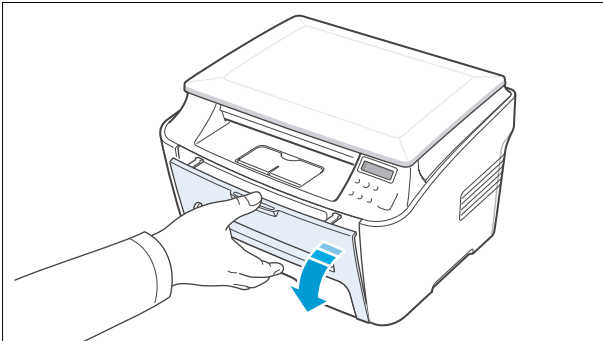

2. Lightly pushing the used cartridge down, pull it out.

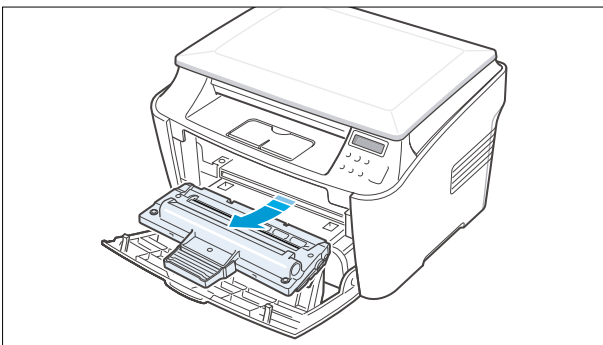

Note : Help the environment by recycling your used toner cartridge. Refer to the recycling brochure packed with the toner cartridge for details.

3. Unpack the new toner cartridge and gently shake it horizontally four or five times to distribute the toner evenly inside the cartridge.

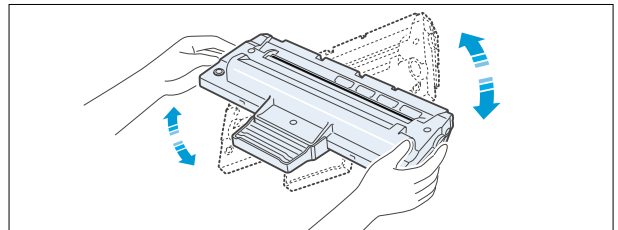

4. Save the box and the cover for shipping. Slide the new toner cartridge in until it locks into place.

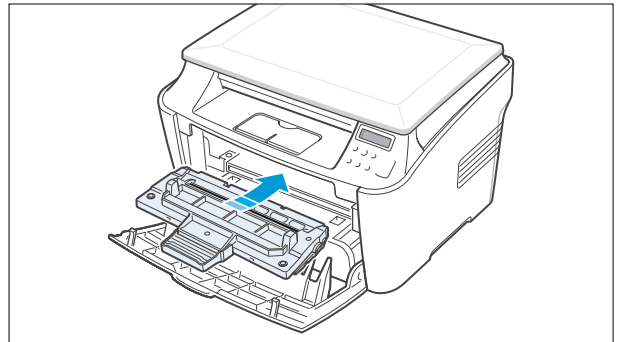

7.5.3 Standard of guarantee for consumable parts.

Please refer to User's Manual or Instructions on Printer Consumables SVC manual for the criteria for judging the quality of consumable parts the standard of guarantee on those parts.

- **Spotting a refilled cartridge by eye.**

One way security screws are used in the manufacture of the cartridge – check if these are damaged.

7.5.4 Signs and Measures of Poor toner cartridge

Fault	Signs	Cause & Check	Solution
<p>Light image and partially blank image (Cartridge life is ended.)</p> <div data-bbox="162 519 354 743" style="border: 1px solid black; padding: 5px; margin-top: 10px;"> Digital Printer Digital Printer Digital Printer Digital Printer Digital Printer </div>	<ul style="list-style-type: none"> • The printed image is light or dirty and untidy. • Parts of the image are not printed. • Periodically a "tick tick" noise occurs. 	<ol style="list-style-type: none"> 1. If the image is light or dirty and untidy - Shake the toner cartridge and then recheck. OK: Lack of toner, so the life is nearly expired. 2. Some part of image is not printed - Shake the toner cartridge and then recheck. (1)NG: clean the LSU window with a cotton swab, then recheck. (2)OK: Lack of toner, so the life is nearly closed. 3. Periodically a noise like "tick tick" occurs - Measure the time between ticks. 4. White vertical stripes on the whole or part of the page : Shake the toner cartridge and then recheck. OK: Lack of toner, so the life is nearly expired 	<ol style="list-style-type: none"> 1. All of 1, 2, 3 If image quality improves by shaking, replace with a new toner cartridge. Perhaps up to 100 pages left before out of toner. 2. For item 2- If image quality improves after cleaning the LSU window then the toner cartridge is normal. (Contamination on the LSU window has caused image quality problems.) 3. For item 3- If the time between ticks is about 2 seconds, the toner inside the toner cartridge is almost exhausted. (Purchase and replace with a new toner cartridge. Perhaps up to 200 pages left before out of toner) 4. For item 3- This is a phenomenon caused by lack of toner, so replace the toner cartridge.
<p>Toner Contamination</p>	<ul style="list-style-type: none"> • Toner contamination of the printed page at regular intervals down the page. • Random Toner contamination over the whole or large parts of the paper surface. 	<ol style="list-style-type: none"> 1. Contamination at regular intervals. (a)Check the distance between contamination marks. (b)Check the appearance of both ends of the toner cartridge OPC drum. 2. Random page contamination. (a) Check that the terminals (contact points) of the toner cartridge and the set are clean. (b) Check that the terminals (contact points) of the toner cartridge and the set are not damaged. 	<ol style="list-style-type: none"> 1.(a) Refer to section 6.5 1.(b) If both ends of the OPC drum are contaminated with toner: Check no. of pages printed using this cartridge – perhaps waste toner collector is full. 2. Clean all HV contacts. If the problem persists replace the cartridge.

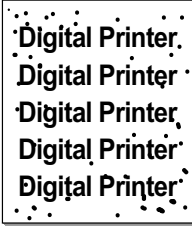
Fault	Signs	Cause & Check	Solution
<p>White Black spot</p> 	<ul style="list-style-type: none"> • Light or dark black dots on the image occur periodically. • White spots occur in the image periodically. 	<ol style="list-style-type: none"> 1. If light or dark black dots occur at regular intervals this is because the toner cartridge rollers are contaminated with foreign substance or paper particles. (1)38mm interval : Charge roller (2)95mm interval : OPC cycle 2. If white spots occur in a black image at intervals of 95mm, or black spots occur elsewhere, the OPC drum is damaged or foreign substance is stuck to the surface. 3. If a black and white or graphic image is partially broken at irregular intervals, the transfer roller's life has been expired or the transfer voltage is abnormal. 	<ol style="list-style-type: none"> 1. For item 1 - Run OPC Cleaning Mode Print 4-5 times repeatedly to remove excess toner. Especially check for foreign substances on the OPC surface Clean with a clean gauze moistened with IPA (Isopropyl Alcohol) take care not to damage the OPC surface. ▲ Never use other forms of alcohol. 2. For Item 2 - If running OPC Cleaning Mode Print 4-5 times does not resolve the problem : at intervals of 37.7mm - place the toner cartridge. : at intervals of 75.5mm – clean OPC drum. 3. For item 3 - Change the transfer roller because the life of the transfer roller has expired. (Check the transfer voltage and readjust if necessary.)
<p>Recycled product</p>	<ul style="list-style-type: none"> • Poor appearance of the toner cartridge. • Dirty or rough printouts. • Bad background in the image. 	<ol style="list-style-type: none"> 1. Poor appearance of the toner cartridge. (a)Check for damage to label and if different materials are used. (b)Check the appearance of parts of the toner cartridge, such as frame, hopper, screws 2. Unclean and rough printouts. (a)Check that the terminals (contact point) of the toner cartridge and the set are clean. (b)Check that the terminals (contact point) of the toner cartridge and the set are not damaged. 	<ol style="list-style-type: none"> 1. For Item 1 the cartridge is judged to be a recycled product - (a) If there is any evidence of disassembling the toner cartridge. (b) If materials other than normal parts of the toner cartridge are added or substituted. 2. Clean all HV contacts. If the problem persists replace the cartridge. <p>Note If the cartridge is judged to be recycled then these types of problems can occur when the toner cartridge is recycled over 2 times.</p> <p>If 'nearly empty' cartridges are collected for re-use this is judged as recycling the toner cartridge.</p>

Fault	Signs	Cause & Check	Solution
<p>Ghost & Image Contamination</p>	<ul style="list-style-type: none"> • The printed image is too light or dark, or partially contaminated black. • Totally contaminated black. (Black image printed out) • The density of printouts is too dark and ghost occurs. 	<ol style="list-style-type: none"> 1. The printed image is too light or dark, or partially contaminated black. <ol style="list-style-type: none"> (a) Check if foreign substance or toner are stuck to the terminals (point of contact) of the toner cartridge or set. (b) Check if the terminal assembly is normal. 2. Totally contaminated black. (Black image printed out) <ol style="list-style-type: none"> (a) Check if foreign substances are stuck to the terminal (point of contact) of the toner cartridge or set. (b) Check if the terminal assembly is normal. (Especially check the charge roller terminal.) 3. The printed image is dark and ghost occurs. <ol style="list-style-type: none"> (a) Check if foreign substances are stuck to the terminal (point of contact) of the toner cartridge or set. (b) Check if the terminal assembly is normal. (Especially check the developer roller terminal.) 	<ol style="list-style-type: none"> 1. All of Items 1, 2, 3 <ol style="list-style-type: none"> (a) Clean the contacts on the toner cartridge. (b) Clean the contact points on the set. (c) If the terminal assembly is damaged repair or replace the terminals in the set or replace the cartridge 2. In Item 2 This is particularly related to problems with the charge roller contact. Pay close attention to the charge roller contacts. 3. In Item 3 This is particularly related to problems with the developer bias voltage contact. Pay close attention to the charge roller contacts.

7.6 Software Problems – Causes and Solutions

7.6.1 The printer is not working (1)

Description While Power turned on, the printer is not working in the printing mode.

Check and Cause	Solution
<p>1. Run Self-Test Mode: using the menu buttons print the test page. (Menu, Enter, Enter).</p> <p>2. Check that the PC and the printer are properly connected and that the toner cartridge installed correctly.</p> <p>3. Printing is not working in the Windows.</p> <p>4. Check that the printer cable is directly connected to the printer.</p>	<p>1. If the test print works that means there are no problems in the printer itself. If the test printing does not work that means the printer is faulty and the problem is not due to computer software or driver settings.</p> <p>2. Replace the printer cable. If the problem is not solved even after the cable is replaced, check the amount of the remaining toner. (refer to Toner Cartridge Service 7-6, Page 7-25)</p> <p>3. Check that the connection between PC and printer port are correct. If you use windows, check that the printer driver in the controller is set up correctly set up, the correct port is selected and 'Use On-line' is selected in the driver. If the printer driver is properly set up try printing a test page from the driver properties. Check in which program printing is not working. Try opening 'Memo Pad' and printing. If the printer is not working in a certain program, adjust the setup within that program. Sometimes, the printout is normal within the Windows basic programs, but it's not working in a particular program. In this case, uninstall and re-install the new driver. If the printer is not working in the Windows basic programs and you are printing using the parallel port check the port setting in CMOS is on ECP and that the address is IRQ 7 and 378 (for parallel port 1). Try using USB instead of parallel – or vice versa.</p> <p>4. If you have other devices that need to share the printer port try temporarily disconnecting these devices (and perhaps even uninstalling their drivers) to ensure the printer works by itself. If you are using a USB hub try connecting directly to the back of the PC instead.</p>

7.6.2 The printer is not working (2)

- **Description** After receiving the print command there is no response at all or print speed is low due to wrong setup of the environment rather than malfunction of the printer itself.

Check and Cause	Solution
<ol style="list-style-type: none"> 1. Ensure you have sufficient free hard disk space for the temporary work files created during printing. 2. Printing error occurs even if there is enough space in the hard disk. 3. Check the parallel-port-related items in the CMOS Setup. 4. Reboot the system to print. 	<ol style="list-style-type: none"> 1. Not working with the message 'insufficient printer memory' means there is a hard disk space problem rather than a printer RAM problem. In this case provide more space on the hard disk. Secure more space using the disk utilities program. 2. The connection of the cable and printer port is not correct. Check that the cable is properly connected and if you are using the parallel port check that the port settings in CMOS is correct. 3. For the printer port, Select ECP. SPP and normal normal modes support 8-bit data transfer, while ECP Mode supports 12-bit data transfer. 4. If the regular font is not printing, the cable or the printer driver may be defective. Turn the PC and printer off, and reboot the system to print again. If not solved, double-click the printer in my computer. If the regular fonts are not printed this time again, the cable must be defective so replace the cable with new one.

7.6.3 Abnormal Printing

- **Description** Printing does not work – even after replacing the cable
Printer does not work at all or strange fonts are printed,

Check and Cause	Solution
<ol style="list-style-type: none"> 1. Set up the parallel port using CMOS SETUP. 2. Printer Driver Error. 3. Error message "insufficient memory". (The printing job sometimes stops due to insufficient virtual memory, this is caused by insufficient space on the hard disk.) 	<ol style="list-style-type: none"> 1. Ensure that ECP (best) or SPP is selected in the CMOS (BIOS) setup. 2. Ensure that the correct driver is loaded. Use the driver supplied on the CD or downloaded from the Samsung web site. DO NOT use the Microsoft driver supplied with the Windows operating system. If the printer is a GDI or SPL type printer ensure that ALL OTHER GDI or SPL drivers are uninstalled as Windows allows only 1 of this type of driver to be loaded. 3. Delete any unnecessary files to secure enough space on the hard disk and start the print job again.

7.6.4 SPOOL Error

Description SPOOL (simultaneous peripheral operations online) is the process Windows uses to manage print jobs. Jobs are processed and then stored on the hard disk until the printer is ready to accept them

Check and Cause	Solution
1. Insufficient space on the hard disk in the directory assigned for the basic spool.	1. Delete any unnecessary files to provide more space for spool storage.
2. If previous printing errors were not solved.	2. There may be files from previous failed print jobs on the hard disk with the name in the form '*.jnl'. Delete these files and Reboot Windows to restart the printer.
3. There may be conflict with other drivers or programs.	3. Shut down all other programs except the current one, if possible.
4. When an application program or the printer driver is damaged.	4. Delete the printer driver completely and reinstall it.
5. When some files related to the OS are damaged or virus infected.	5 After rebooting the computer, check for viruses, restore the damaged files and reinstall the application program which is not working properly.
6. Memory is less than suggested.	6. Add up more memory to the PC.

⚠ How to delete the data in the spool manager.

In the spool manager, the installed drivers and the list of the documents waiting to be printed are shown. Select the document to be deleted and check delete in the menu.

If the job you are deleting is the current job when you delete the job data that has already been transferred to the printer's memory will still be printed. If there is a problem with the printer (out of toner, offline, out of paper etc.) the job may take a long time to delete as it must wait for a time out.

MEMO



8. Exploded Views and Parts List

- 8.1 Main Assembly page(8-2)
- 8.2 Frame Assembly page(8-4)
- 8.3 Scanner Unit Assembly page(8-7)
- 8.4 Fuser Unit Assembly page(8-9)
- 8.5 Middle Cover Unit Assembly page(8-11)
- 8.6 Driver Unit Assembly page(8-13)
- 8.7 Cassette Unit Assembly page(8-14)

- Deal drawings and service parts are declared for the items with higher rate of inferiority and replaceable in the level of service description only.
- If inferiority occurs, you can replace the parts by the unit declared in deal drawings and service items.

Way to observe Part Code & Description

Part code and Description is quoted and controlled by determined standard. Refer to this determined standard, it will help with ordering Part.

- There are two kinds of Part code inscription type.

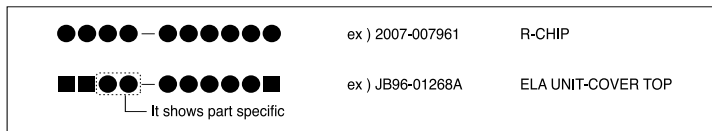

(● : figure, ■ : character (alphabet))

Type 1 : Controlled by Company : It can be commonly used for all kinds of product SEC produce. Mostly, electronics Parts.

Type 2 : Controlled by Division : It is used or one produce. Mostly, Mostly, mechanical Parts.

- **A/S privately used part** : It is only used for A/S .
- **Ass'y part** : Assembled by more than 2 Parts. If necessary part is not A/S Part, Ass'y part including necessary par can be used. It is shown in the diagram and drawing of SVC manual.
- Ass'y part and A/S privately used Part is distinguished by part Code and Description. The are inscription type 2. It is recognized by Part character and front side of description.

DIVISION	PART CODE	DESCRIPTION
A/S Private	**81-***** (JB81-00039A)	AS-***** (AS-USE)
ASS'Y Part	**75-***** (JB75-00068A)	MEC-***** (MEC-CHUTE)
ASS'Y Part	**92-***** (JB92-01131A)	PBA ***** (PBA MAIN-CONTROLLER)
ASS'Y Part	**97-***** (JB97-01089A)	MEA ***** (MEA UNIT-PULLEY IDLE)

8.1 Main Assembly

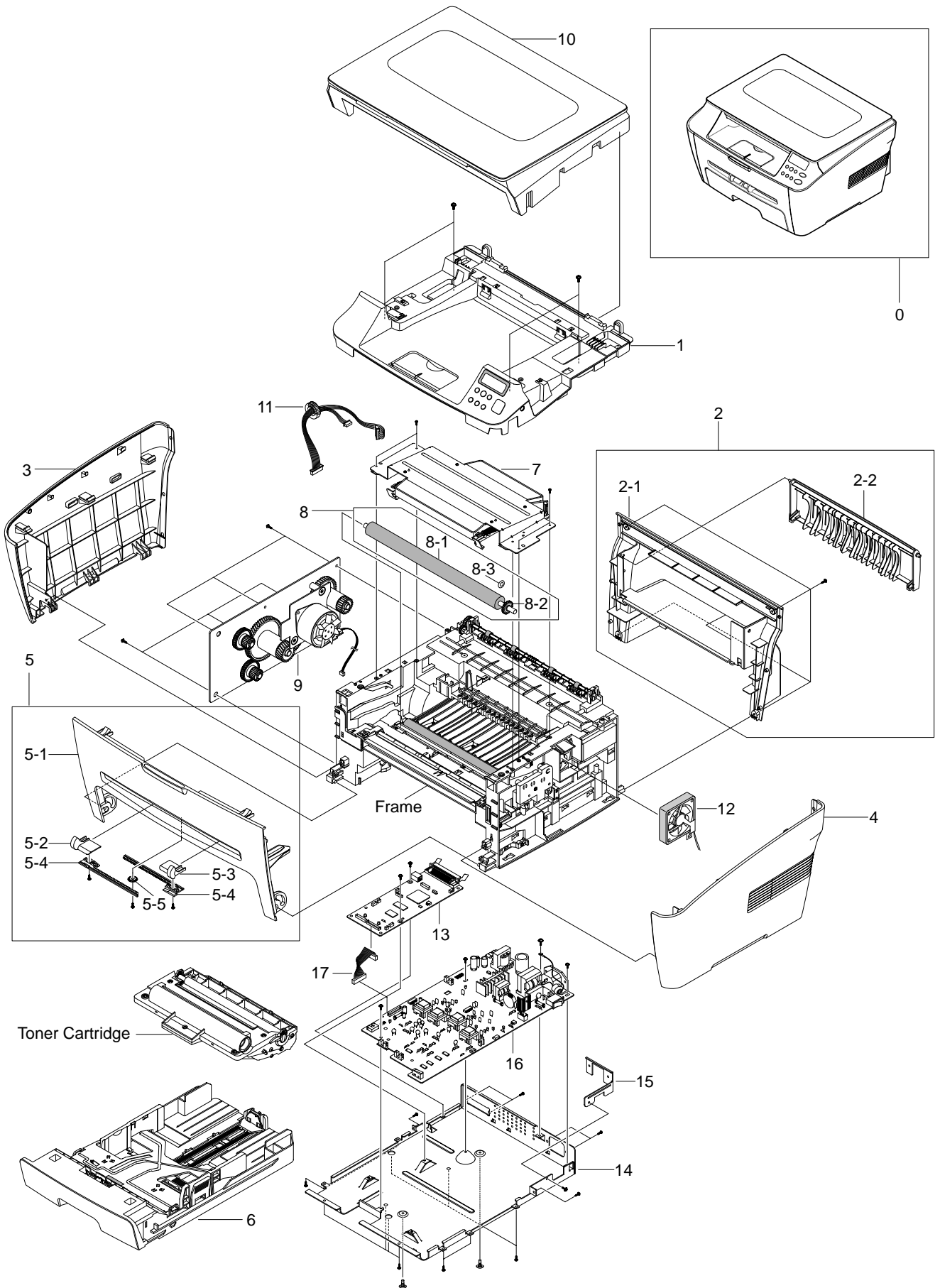

Main Assembly Parts List

SA : Service Available

O : Service available X : Service not available

No.	Description	SEC.Code	Q'ty	SA	Remark
0	SCX-4100				
1	MEA UNIT-COVER MIDDLE	JC97-01958A	1	O	SCX-4100
2	MEA UNIT-COVER REAR	JC97-01959A	1	O	SCX-4100
2-1	COVER-M_REAR	JC63-00475A	1	X	
2-2	COVER-M_REAR DOOR	JC63-00476A	1	X	
3	COVER-M_SIDE_L	JC63-00472A	1	O	
4	COVER-M_SIDE_R	JC63-00471A	1	O	
5	MEA UNIT-COVER FRONT	JC97-01960A	1	O	SCX-4100
5-1	COVER-M_FRONT	JC63-00477A	1	X	
5-2	ADJUST-M_MANUAL_L	JC70-00481A	1	X	
5-3	ADJUST-M_MANUAL_R	JC70-00482A	1	X	
5-4	ADJUST RACK-M_MANUAL	JC70-00304A	2	O	
5-5	GEAR-RACK PINION	JC66-00387A	1	X	
5-6	LABEL(P)-EXTRACT(DEVE)	JC68-01085J	1	X	
S	SCREW-TAPTITE	6003-000264	3	X	
6	MEA UNIT-CASSETTE_MB	JC97-01914A	1	O	SCX-4100
7	UNIT-HUMMING_VE LSU	JC59-00018C	1	O	
8	MEA ETC-TR	not assign	1	O	
8-1	ROLLER-TRANSFER	JC66-00725A	1	O	
8-2	GEAR-TRANSFER	JC66-00395A	1	O	
8-3	PPR-SPACER-TR	JC72-00851A	2	X	
9	ELA-UNIT-DRIVE	JC96-03138A	1	O	
10	ELA-UNIT-COVER PLATEN	JC96-03050A	1	O	
11	CBF JARMESS-LSU	JC39-00242A	1	O	
12	FAN-DC	3103-001085	1	O	
13	PBA MAIN-CONTROLLER	JC92-01594A	1	O	
14	MEA UNIT-SHIELD ENGINE	JC97-01792A	1	O	
15	BRACLET-P-INLET	JC61-00601A	1	O	
16	SMPS-V1, 110V	JC44-00072A	1	O	▲ 110V
	SMPS-V2, 220V	JC44-00073A	1	O	▲ 220V
17	CBF HARNESS-ENGINE	JC39-00240A	1	O	

8.2 Frame Assembly

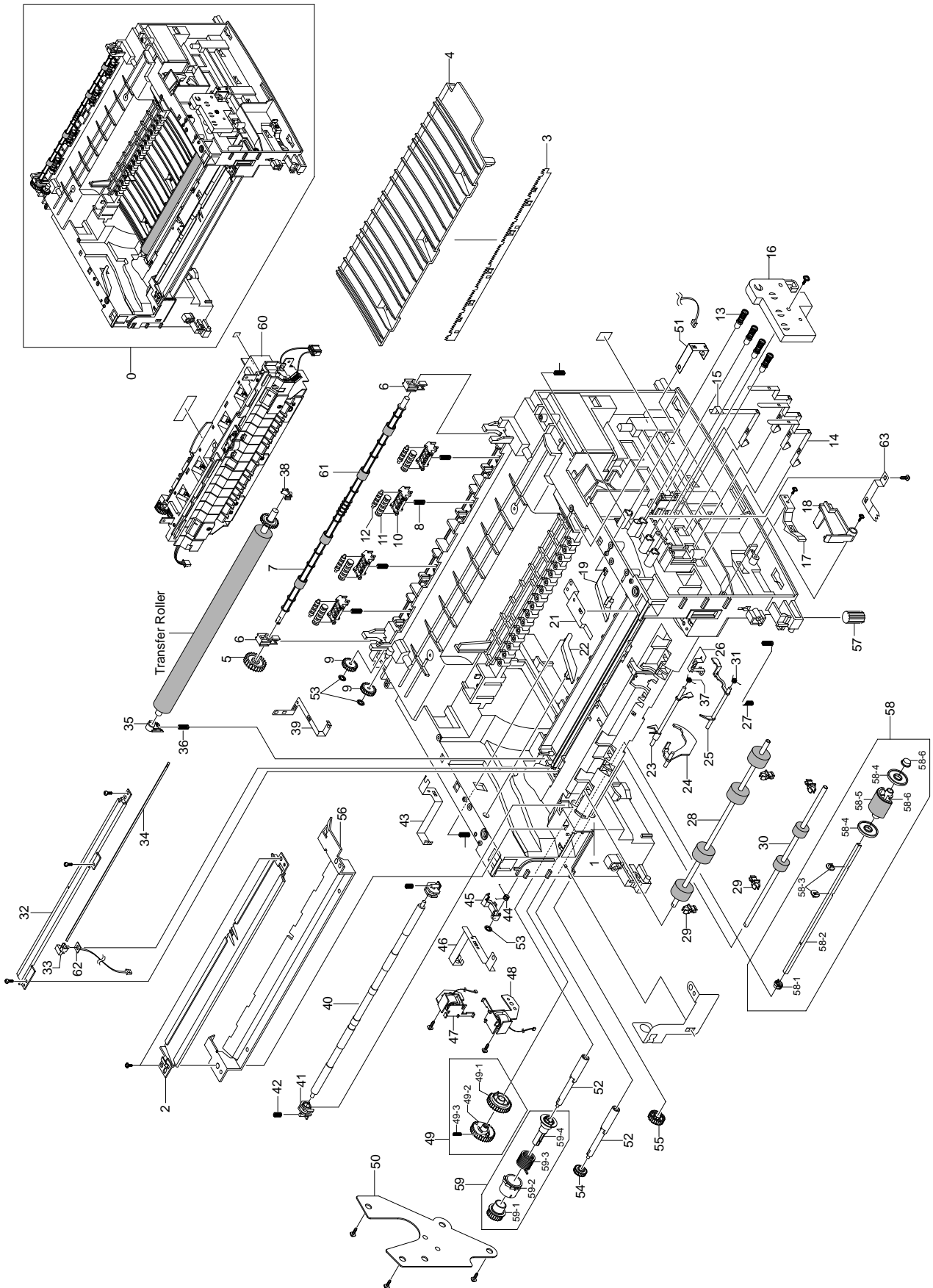

Frame Unit Assembly Parts List

SA : Service Available

O : Service available X : Service not available

No.	Description	SEC.Code	Q'ty	SA	Remark
0	ELA UNIT-FRAME LOWER, 110V	JC96-03137A	1	O	▲ 110V
	ELA UNIT-FRAME LOWER, 220V	JC96-03137B	1	O	▲ 220V
1	FRAME-M-BASE	JC61-00579A	1	O	
2	GUIDE-P-PAPER	JC61-00943A	1	O	
3	PLATE-P-SAW	JC61-00604A	1	O	
4	GUIDE-M-TR RIB	JC61-00933A	1	O	
5	GEAR-EXIT F/DOWN	JC66-00038A	1	O	
6	HOLDER BEARING EXIT F/DOWN	JC61-00829A	2	X	
7	ROLLER-EXIT F/DOWN	JC66-00378A	1	O	
8	SPRING-CS	6107-001163	4	O	Spring Exit
9	PMO-GEAR_EXIT_DRV16	JC72-00143A	2	X	
10	HOLDER-M-EXIT F/DOWN	JC61-00582A	4	O	
11	PMO-ROLLER_EXIT,MAIN	JC72-41081B	4	X	
12	PMO-ROLLER_EXIT,FR	JC72-41082B	4	X	
13	MEC-TERMINAL	JC75-00049A	4	O	
14	IPR-P-TERMINAL CON	JC70-00312A	3	O	
15	IPR-P-TERMINAL CR	JC70-00313A	1	O	
16	HOUSING-TERMINAL	JC61-00592A	1	O	
17	PMO-LOCKER CST	JC72-00983A	2	O	
18	PMO-ACTUATOR CVR OPEN	JC72-00974A	1	O	
19	PMO-PLATE GUIDE DEVE_R	JC72-00985A	1	O	
20	SPRING ETC-GUIDE DEVE	JC61-70932A	2	O	
21	IPR-P-GROUND_GUIDE PAPER	JC70-00458A	1	O	
22	PMO-PLATE GUIDE DEVE_L	JC72-00984A	1	O	
23	PMO-ACTUATOR FEED	JC72-00976A	1	O	
24	PMO-ACTUATOR EMPTY	JC72-00975A	1	O	
25	PMO-ACTUATOR MANUAL	JC72-00977A	1	O	
26	IPR-P-GROUND_EARTH TR	JC70-00309A	1	X	
27	SPRING-ETC	6107-001162	1	O	
28	ROLLER-FEED ROLLER 1	JC66-00526A	1	O	
29	PMO-BUSHING FEED	JC72-00382B	4	O	
30	ROLLER-FEED	JC66-00598A	1	O	
31	SPRING-TS	6107-001165	1	X	Spring-act,Manual
32	IPR-P-EARTH TRANSFER	JC70-00307A	1	O	
33	HOLDER-PTL	JC61-00583A	1	O	
34	LENS-PTL	JC67-00027A	1	O	
35	BUSH-M-TR L	JC61-00588A	1	O	
36	SPRING ETC-TR L HAWK	JC61-00047A	1	X	
37	SPRING-TS	6107-001165	1	X	Spring-act,Feed
38	PMO-BUSHING_TR(L)	JC72-00102A	1	O	

Frame Unit Assembly Parts List(Cont.)

SA : Service Available
 O : Service available X : Service not available

No.	Description	SEC.Code	Q'ty	SA	Remark
39	IPR-P-GROUND_FUSER	JC70-00310A	1	O	
40	SHAFT-FEED IDLE	JC66-00527A	1	O	
41	BUSH-M-FEED IDLE	JC61-00585A	2	O	
42	SPRING ETC-TR	JC61-70958A	2	X	Spring Feed Idle
43	IPR-P_GROUND_DRIVE2	JC70-00335A	1	O	
44	SPRING-TS	6107-001170	1	O	Spring-cam Pick-up
45	CAM-M-PICK_UP	JC66-00377A	1	O	
46	IPR-P-GROUND_DRIVE	JC70-00308A	1	O	
47	SOLENOID-HB (PICK-UP)	JC33-00009A	1	O	
48	SOLENOID-HB (MANUAL)	JC33-00010A	1	O	
49	AS-GEAR PICK_UP	JC81-01692A	1	O	
49-1	PMO-GEAR PICK_UP B	JC72-00980A	1	O	
49-2	PMO-GEAR PICK_UP A	JC72-00979A	1	O	
49-3	SPRING-CS	6107-001167	1	X	Spring-Pick-up gear
50	BRACKET-P-FEED	JC61-00602A	1	O	
51	IPR-P-GROUND_TR	JC70-00311A	1	O	
52	SHAFT-FEED	JC66-00398A	2	O	
53	RING-CS	6044-000001	3	X	
54	GEAR-FEED 2	JC66-00394A	1	O	
55	GEAR-IDLE 23	JC66-00396A	1	O	
56	GUIDE-P-PAPER	JC61-00718A	1	O	
57	FOOT-FRONT	JC61-00836A	2	O	
58	AS-PICK UP	JC81-01693A	1	O	
58-1	BUSH-M-PICK_UP L	JC61-00586A	1	O	
58-2	SHAFT-P-PICK_UP	JC66-00399A	1	O	
58-3	STOPPER-PICK_UP	JC61-00593A	2	X	
58-4	PMO-IDLE PICK_UP	JC72-00982A	2	O	
58-5	SPONGE-ROLLER PICK_UP	JC72-01231A	1	O	
58-6	BUSH-M-PICK_UP R	JC61-00587A	1	O	
58-7	HOUSING-M-PICK_UP	JC61-00591A	1	O	
59	MEA UNIT-CLUTCH	JC97-01788A	1	O	
59-1	GEAR-FEED 1	JC66-00393A	1	O	
59-2	PMO-COLLAR_SPRING	JC72-00978A	1	O	
59-3	SPRING-TS	6107-001171	1	X	
59-4	PMO-HUB CLUTCH	JC72-00981A	1	O	
60	ELA HOU-FUSER_220V	JC96-03135B	1	O	▲ 220V
	ELA HOU-FUSER_110V	JC96-03135A	1	O	▲ 110V
61	RMO-RUBBER EXIT	JC73-40915A	4	O	
62	PBA MAIN-PTL	JC92-01620B	1	X	
63	IPR-GROUND_SAW	JC63-00465A	1	X	

8.3 Scanner Unit Assembly

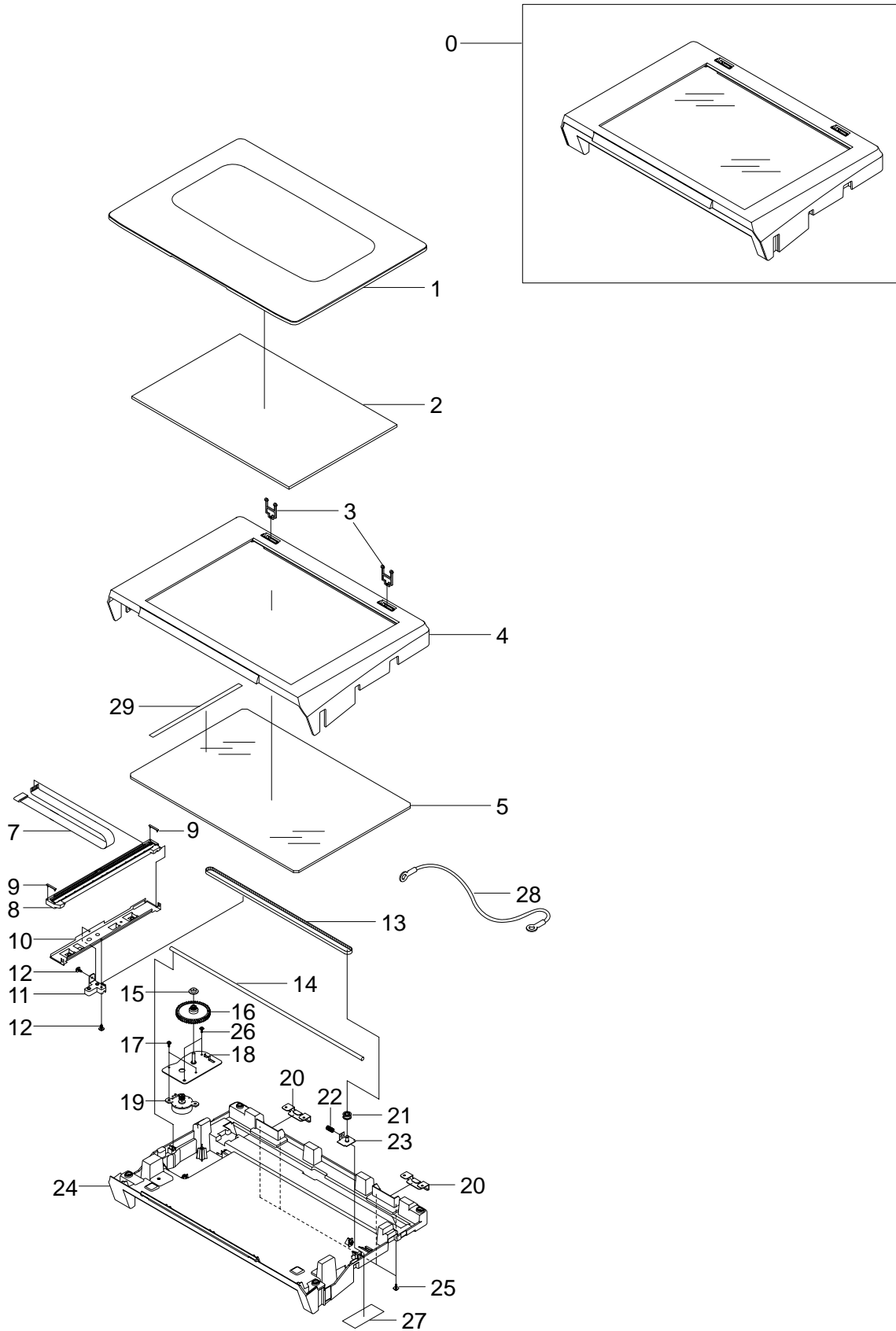

Scanner Unit Assembly Parts List

SA : Service Available

O : Service available X : Service not available

No.	Description	SEC.Code	Q'ty	SA	Remark
0	UNIT SCAN	JC96-03136A	1	O	SCX-4100
1	COVER-M-PLATEN	JC63-00454A	1	X	
2	SHEET-WHITE SPONGE	JC63-00209A	1	O	
3	HINGE PIVOT	JC61-00929A	2	X	
4	COVER-M-SCAN UPPER	JC63-00452A	1	X	
5	GLASS SCAN	JC01-00002A	1	X	
7	CBF SIGNAL-CIS FFC	JC39-00358A	1	X	
8	CIS MODULE	0609-001214	1	O	
9	SLIDER CIS	JC66-00714A	2	X	
10	IPR CARRIAGE-CIS	JC70-00480A	1	X	
11	HOLDER CIS	JC61-00930A	1	X	
12	SCREW-TAPTITE	6003-001064	2	X	
13	BELT-SCANNER	JB66-00007A	1	O	
14	IPR-SHAFT CIS	JC66-00718A	1	X	
15	CAP PULLEY	JC67-00069A	1	X	
16	GEAR-M-PULLEY	JC66-00721A	1	X	
17	SCREW-TAPTITE	6003-000269	2	X	
18	BRACKET SCAN MOTOR	JC61-00952A	1	X	
19	MOTOR STEP-SCAN	JC31-00035A	1	O	
20	BRACKET SCAN L	JC61-00941A	2	X	
21	PULLEY IDLE	JC66-00713A	1	X	
22	SPRING ETC-BELT	6107-001194	1	X	
23	BRACKET PULLEY	JC61-00931A	1	X	
24	COVER-M-SCAN LOWER	JC63-00453A	1	X	
25	SCREW-TAPTITE	6003-000269	4	X	
26	SCREW-TAPTITE	6003-000196	2	X	
27	SHEET SCAN LOWER	JC63-00459A	1	X	
28	CBF HARNESS-OPE	JB39-40532A	1	X	
29	LABEL(P)-SHADING	JB68-00644A	1	X	

8.4 Fuser Unit Assembly

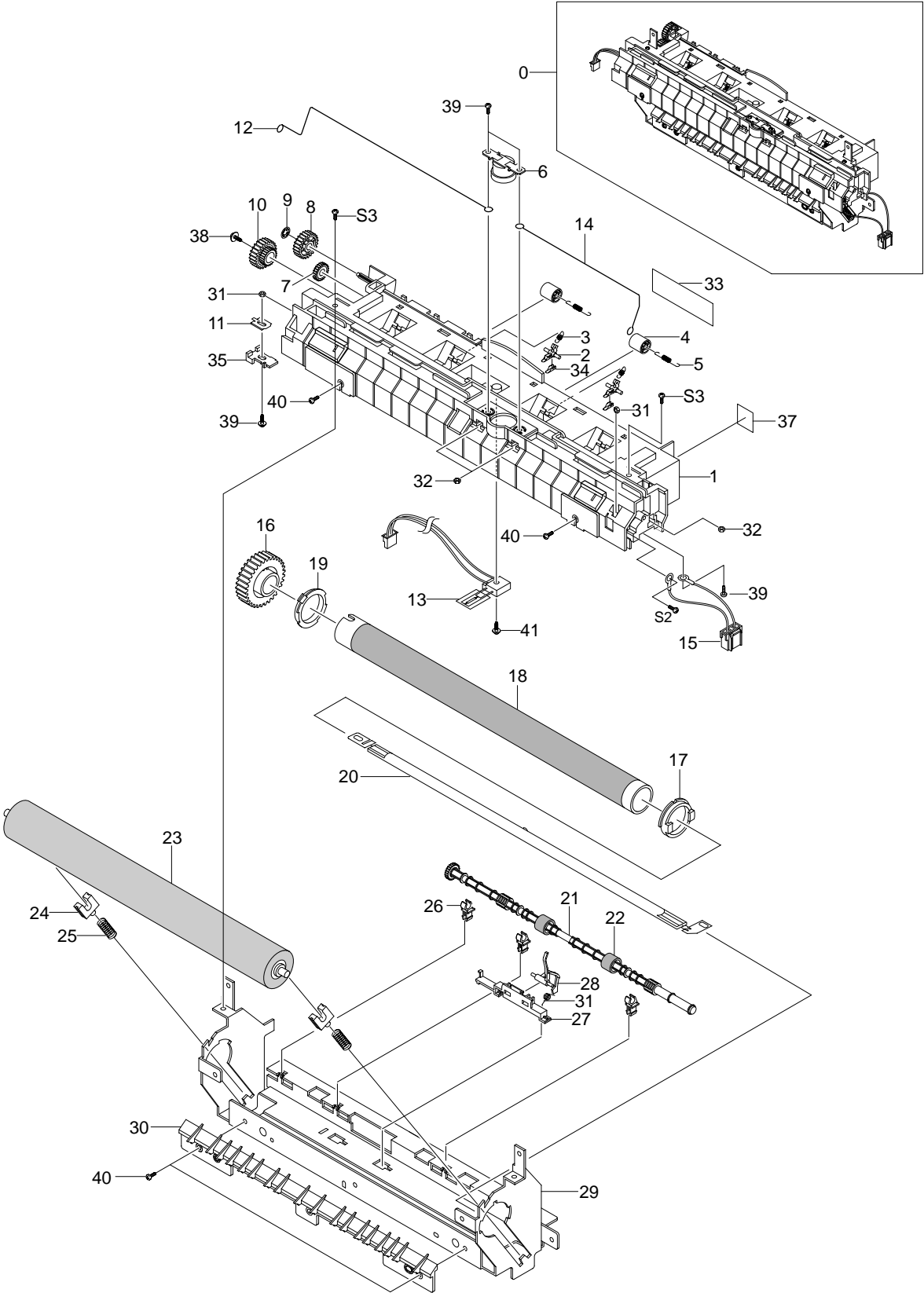

Fuser Unit Assembly Parts List

SA : Service Available
 O : Service available X : Service not available

No.	Description	SEC.Code	Q'ty	SA	Remark
0	ELA HOU-FUSER_220V	JC96-03135B	1	O	▲ 220V
	ELA HOU-FUSER_110V	JC96-03135A	1	O	▲ 110V
1	COVER-M-FUSER	JC63-00478A	1	X	
2	HOLDER-M-PLATE CLAW	JC61-00584A	4	X	
3	SPRING ETC-CLAW	JC61-00064A	4	X	
4	PMO-ROLLER EXIT	JC72-40361A	2	X	
5	SPRING ETC-FUSER EXIT	JC61-70976A	2	X	
6	THERMOSTAT-150	JC47-00005A	1	O	
7	PMO-GEAR_EXIT_DRV16	JC72-00143A	1	X	
8	GEAR-IDLE 23	JC66-00396A	1	X	
9	RING-CS	6044-000001	1	X	
10	GEAR-RDCN 25/15	JC66-00397A	1	O	
11	ELECTRODE_LAMP2	JC70-00466A	1	X	
12	ELECTRODE-WIRE_L	JC70-00450A	1	X	
13	THERMISTOR-NTC	1404-001298	1	O	
14	ELECTRODE-WIRE_R	JC70-00449A	1	X	
15	CBF HARNESS-FUSER 110V	JC39-00239A	1	O	▲ 110V
	CBF HARNESS-FUSER 220V	JC39-00238A	1	O	▲ 220V
16	GEAR-FUSER	JC66-00037C	1	X	
17	BUSH-M-HR L	JC61-00948A	1	X	
18	ROLLER-HEAT	JC71-00012B	1	O	
19	BUSH-M-HR R	JC61-00947A	1	O	
20	LAMP-HALOGEN_110V	4713-001182	1	O	▲ 110V
	LAMP-HALOGEN_220V	4713-001183	1	O	▲ 220V
21	ROLLER-M-EXIT F/UP	JC66-00380A	1	X	
22	RUBBER EXIT	JC73-00017A	2	X	
23	ROLLER-PRESSURE	JC66-00731A	1	O	
24	BEARING-PRESSURE/R	JC66-10901A	2	X	
25	SPRING-ETC-BEARING PR	JC61-00453A	2	O	
26	PMO-BUSHING TX	JC72-00382A	3	X	
27	HOLDER-ACTUATOR	JC61-00581A	1	X	
28	PMO-ACTUATOR_EXIT	JC72-00987A	1	O	
29	FRAME_FUSER	JC61-00946A	1	X	
30	GUIDE-M-INPUT	JC61-00595A	1	X	
31	SPRING-TS	6107-001165	1	X	
32	NUT-HEXAGON	6021-000222	5	X	
33	LABEL(P)-CAUTION, HOT_FUSER	JC68-30928D	1	X	
34	PLATE-P-CLAW	JC61-00605A	4	X	
35	COVER-LAMP_L	JC63-00521A	1	X	

Fuser Unit Assembly Parts List

SA : Service Available

O : Service available X : Service not available

No.	Description	SEC.Code	Q'ty	SA	Remark
36	WASHER-PLAIN	6031-001051	1	X	
37	LABEL(R)-HV FUSER	JC68-00407A	1	X	
38	SCREW-TAPTITE	6006-001078	1	X	
39	SCREW-MACHINE	6006-001193	5	X	
40	SCREW-TAPTITE	6603-000269	6	X	
41	SCREW-TAPTITE	6003-000196	1	X	

8.5 Middle Cover Unit Assembly

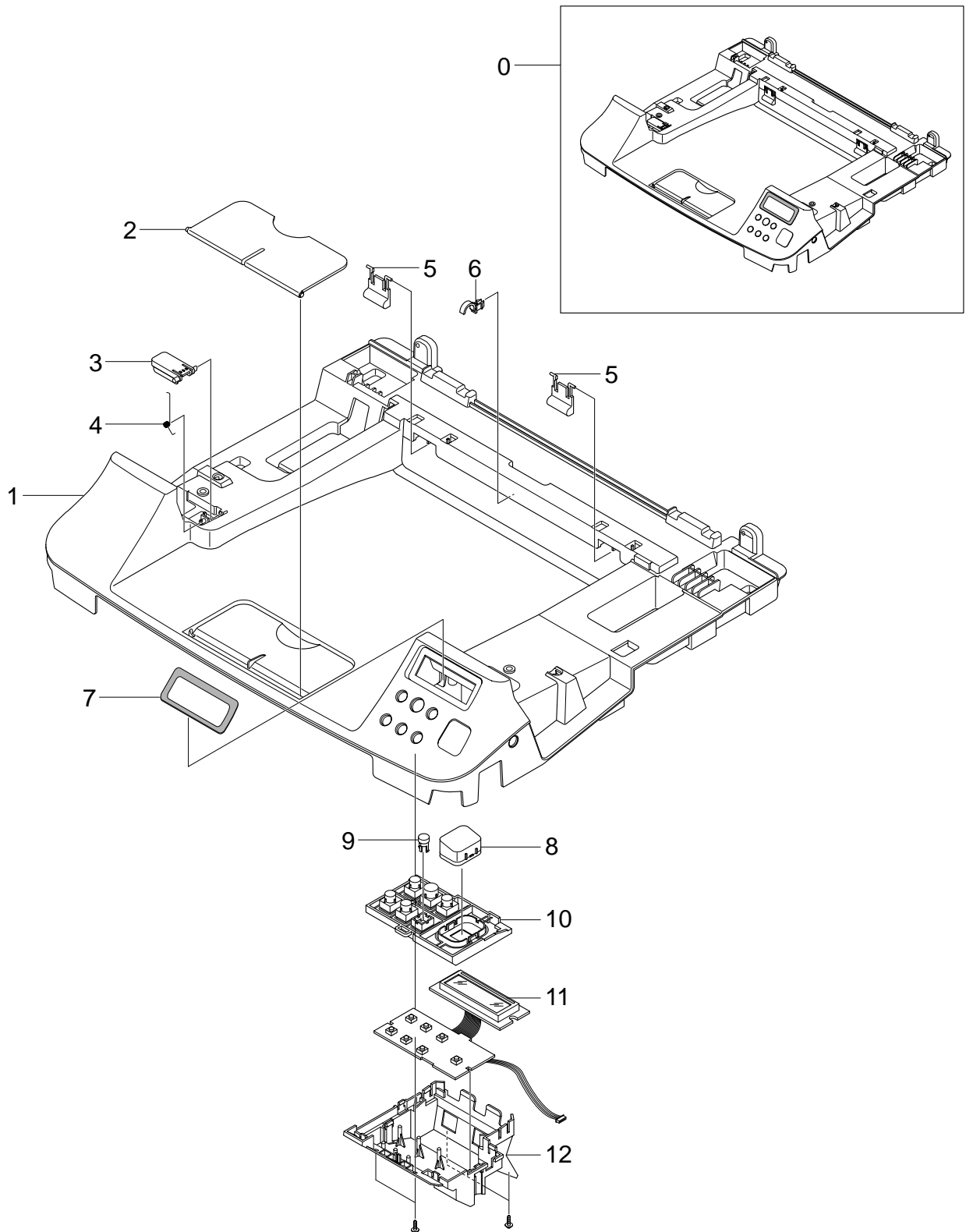

Middle Cover Unit Assembly Parts List

SA : Service Available

O : Service available X : Service not available

No.	Description	SEC.Code	Q'ty	SA	Remark
0	MEA UNIT-COVER MIDDLE	JC97-01958A	1	O	
1	COVER-M_MIDDLE	JC63-00473A	1	X	
2	PMO-STACKER	JC72-01340A	1	X	
3	STOPPER-M-LEVER	JC61-00949A	1	X	
4	SPRING ETC-TS-CHARGE APOLLO	JC61-00026A	1	X	
5	PMO-SUB_M_STACKER	JC72-01343A	2	X	
6	PMO-BUSHING_F/DOWN	JC72-00387A	1	O	
7	WINDOW-M LCD	JC64-00153A	1	X	
8	KEY-M_START	JC64-00151A	1	X	
9	KEY-M_STOP	JC64-00150A	1	X	
10	KEY-M_MENU	JC64-00152A	1	X	
11	PBA SUB-PANEL	JC92-01586A	1	O	
12	COVER-M-PANEL	JC63-00474A	1	X	

8.6 Drive Unit Assembly

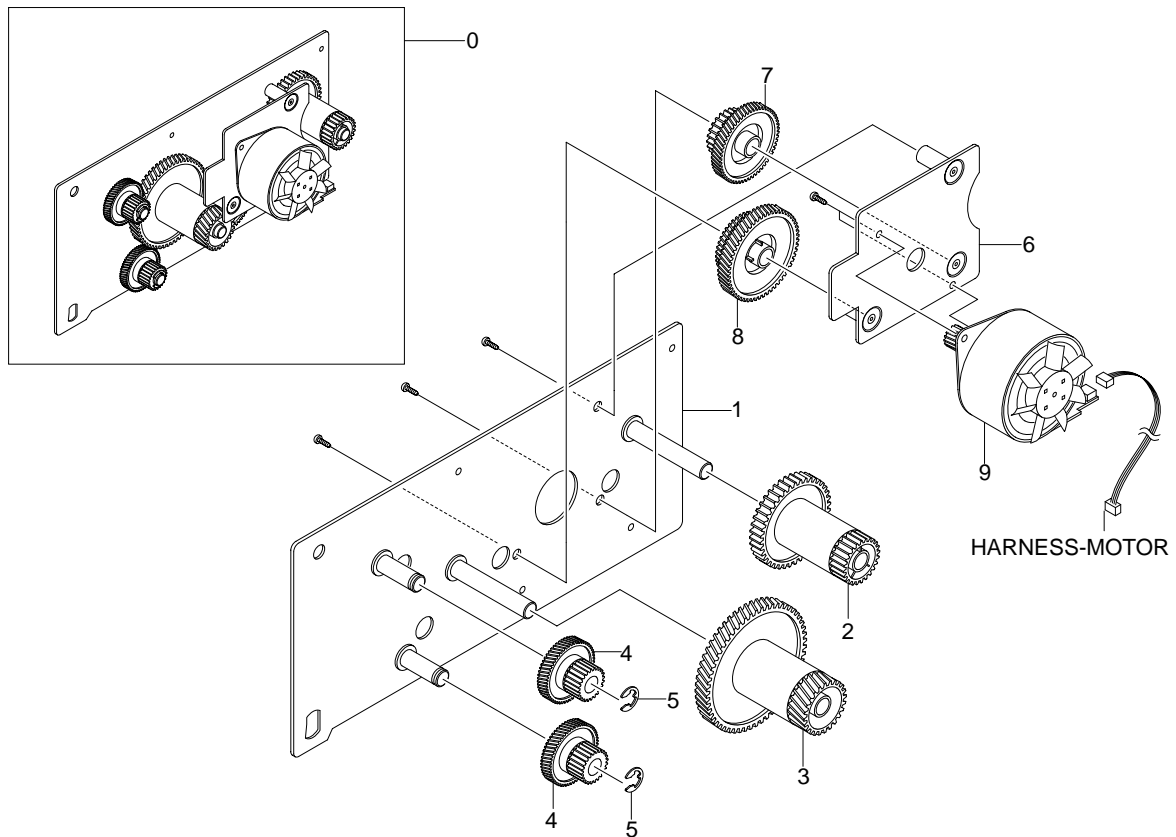

Drive Unit Assembly Parts List

SA : Service Available

O : Service available X : Service not available

No.	Description	SEC.Code	Q'ty	SA	Remark
0	ELA UNIT-DRIVE	JC96-03138A	1	O	
1	BRACKET-P-GEAR 1400	JC61-00598A	1	O	
2	GEAR-RDCN 53/26	JC66-00388A	1	O	
3	GEAR-RDCN 113/33	JC66-00391A	1	O	
4	GEAR-RDCN 57/18	JC66-00389A	2	O	
5	WASHER-PLAIN	6031-000023	2	X	
6	BRACKET-P-MOTOR 1400	JC61-00599A	1	X	
7	GEAR-RDCN 103/41	JC66-00390A	1	O	
8	GEAR-RDCN 90/31	JC66-00392A	1	O	
9	MOTOR STEP 7.5	JC31-00020A	1	O	
10	PMO-IMPELLER_DRV	JC72-00825A	1	X	

8.7 Cassette Unit Assembly

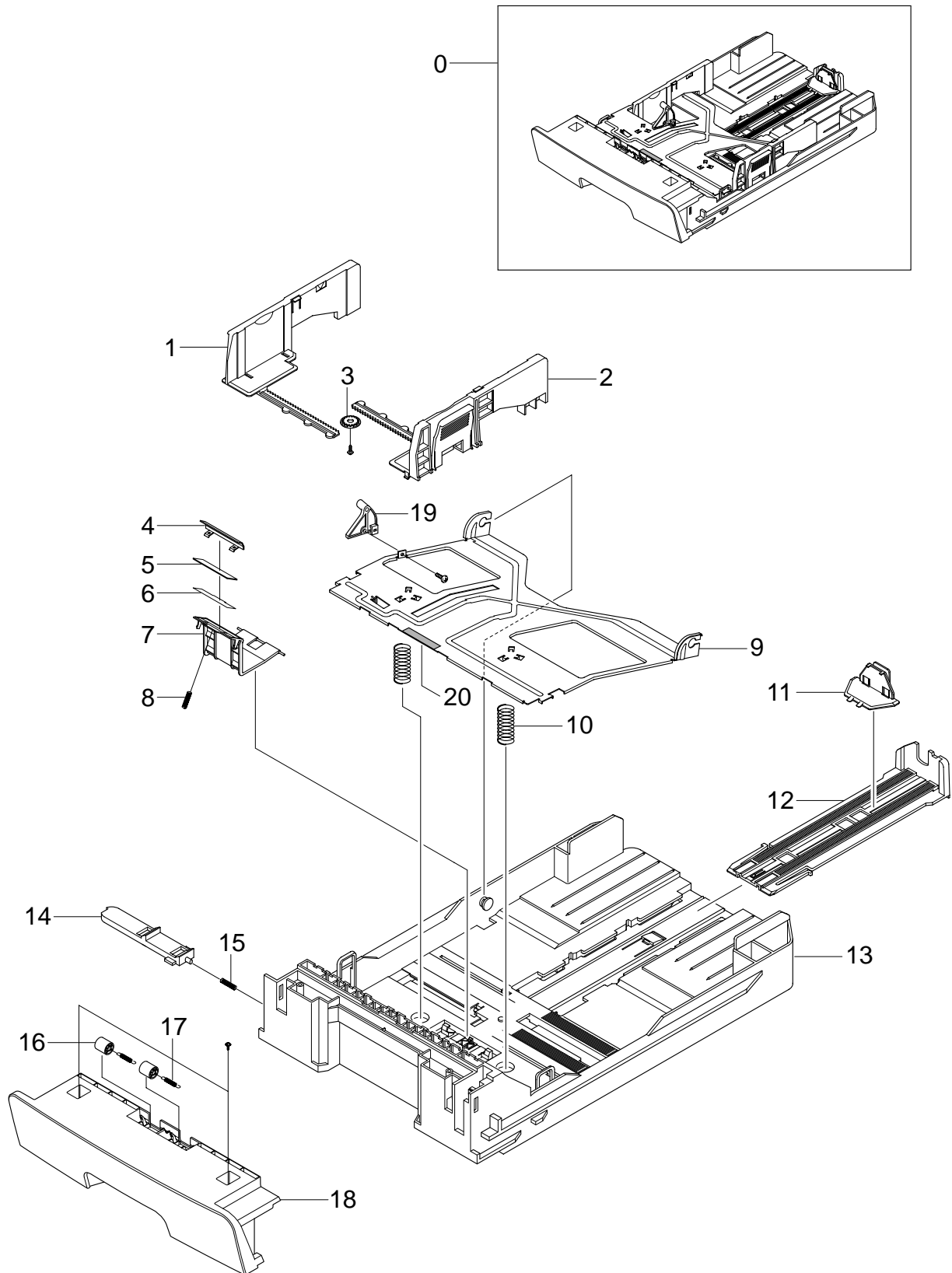

Cassette Unit Assembly Parts List

SA : Service Available

O : Service available X : Service not available

No.	Description	SEC.Code	Q'ty	SA	Remark
0	MEA UNIT-CASSETTE_MB	JC97-01914A	1	O	
1	ADJUST-M-CASSETTE_L	JC70-00300A	1	O	
2	ADJUST-M-CASSETTE_R	JC70-00301A	1	O	
3	GEAR-PINION	JG66-40003A	1	O	
4	IPR-PLATE PAD	JC70-00314A	1	O	
5	RPR-FRICTION PAD	JC73-00140A	1	O	
6	SHEET-HOLDER PAD	JC63-00290A	1	X	
7	HOLDER-M-PAD	JC61-00580A	1	O	
8	SPRING ETC-LOCKER,PLATE	JG61-70531A	1	O	
9	PLATE-P-KNOCK_UP	JC61-00603A	1	X	
10	SPRING-CS	6107-001166	2	X	
11	PMO-EXTENSION SMALL	JC72-00971A	1	O	
12	GUIDE-M-EXTENSION L2	JC61-00918B	1	X	
13	FRAME-M_CASSETTE	JC61-00876A	1	X	
14	PMO-PLATE_LOCKER	JC72-00972A	1	O	
15	SPRING ETC-EXIT ROLL FD	JC61-70911A	1	X	
16	ROLLER-M-IDLE FEED	JC66-00529A	2	O	
17	SPRING-ES	6107-001047	2	X	
18	GUIDE-M_CASSETTE	JC61-00944A	1	X	
19	CAM-M-KNOCK_UP	JC66-00719A	1	X	
20	RPR-PAD CASSETTE	JC73-00141A	1	X	

9. Block Diagram

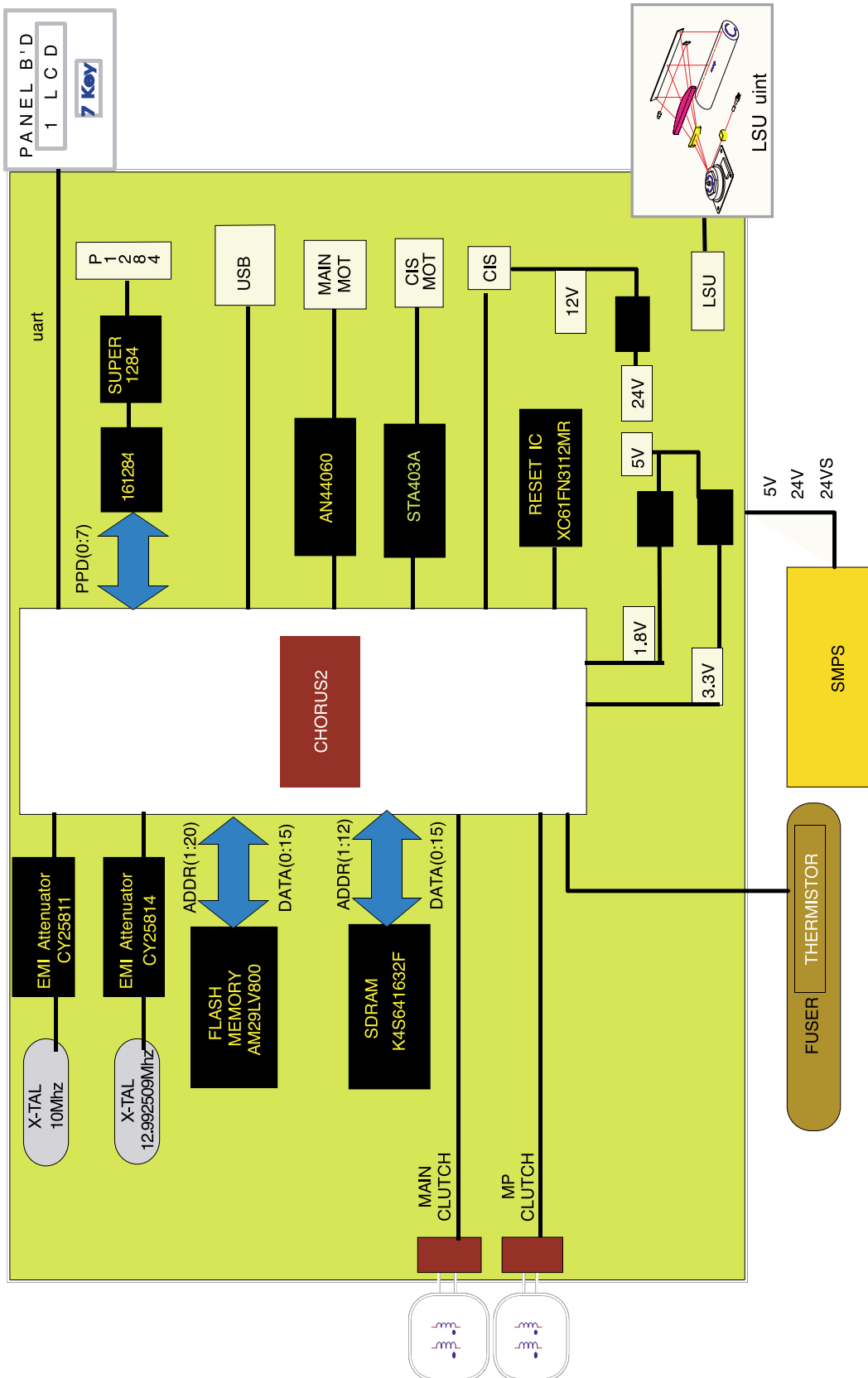

10

10. Connection Diagram

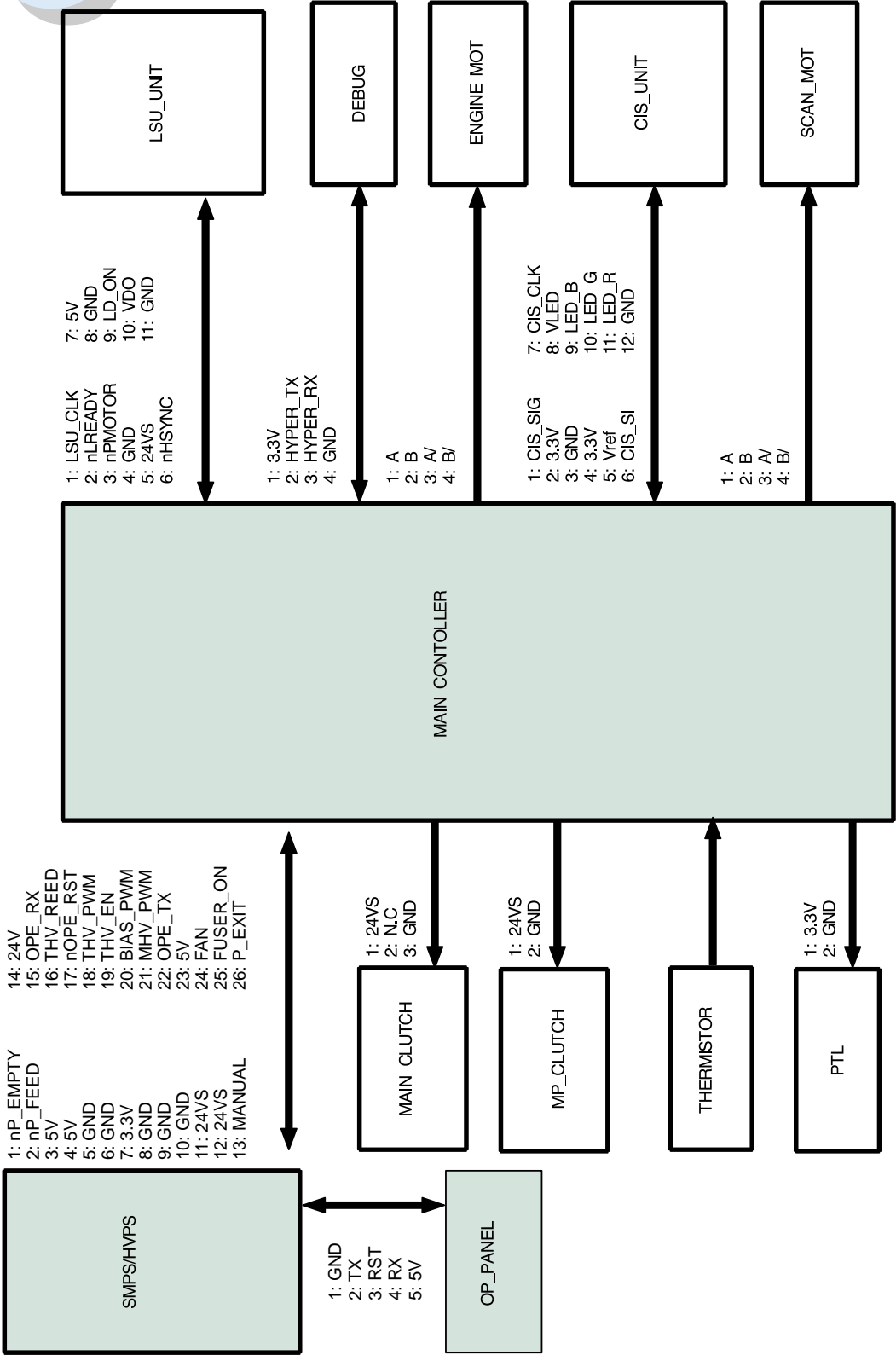



This service manual is also provided on the web,
the ITSELF system of Samsung Electronics Co., Ltd.
<http://itself.sec.samsung.co.kr>

© Samsung Electronics Co.,Ltd. May 2004
Printed in Korea.

VERSION NO. : 1.00 CODE : JC-0125A

www.s-manuals.com